

CDGT3010-2

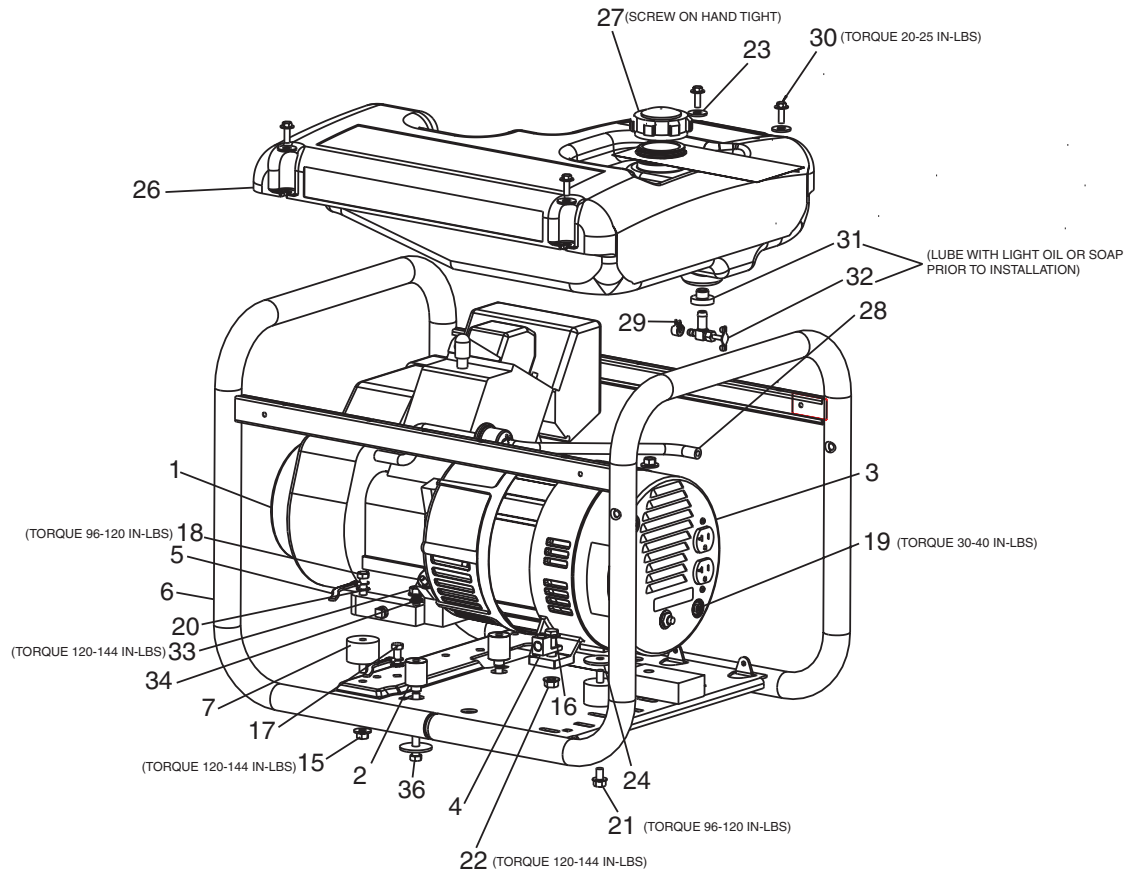

KEY NO.

KEY NO.	DESCRIPTION	PART NUMBER
1	ENGINE (Model #OHH60-71148C)	-
2	RESTRICTOR	GS-0855
3	ENDCOVER	GS-0891
4	GROUND LUG	GS-0117
5	GROUND STRAP	GS-0118
6	FRAME	Z-GS-0846
7	ISOLATORS	GS-0033
15	NUT HEX WIZ LOCK	SSF-8150
16	SCREW	SSF-3140-ZN
17	CAP SCREW 5/16-18 X 3/4	SS-12-CD
18	SCREW, CAP 5/16-18 x 1.25	SSF-605
19	SCREW #10-24 x 1	SSF-553-1
20	LOCK WASHER	SSN-1619-ZN
21	SCREW 5/16-18 x .50	SSF-549
22	LOCK NUT 3/8-16	SSF-8111-ZN
23	WASHER, .875 OD .375 ID	SSN-632
24	WASHER 3/8	SSN-1014-ZN
26	FUEL TANK	Z-GS-0650-1
27	FUEL CAP	GS-0443
28	FUEL HOSE	Z-GS-0225
29	FUEL CLAMP	GS-0227
30	SCREW, 1/4-20 X .75	91895680
31	DRAINCOCK	GS-0446
32	FUEL SHUTOFF VALVE	GS-0437
33	NUT 5/16-18 HEX	SS-656-CD
34	LOCK WASHER	SS-1503-CD
36	SCREW 5/16-18 X 3.00	SSF-550-ZN

Not Shown

MG-GENMAN-F	Operators Manual
D20299	Parts Manual
GS-0660	Engine Manual

CDGT3010-2 (cont'd)

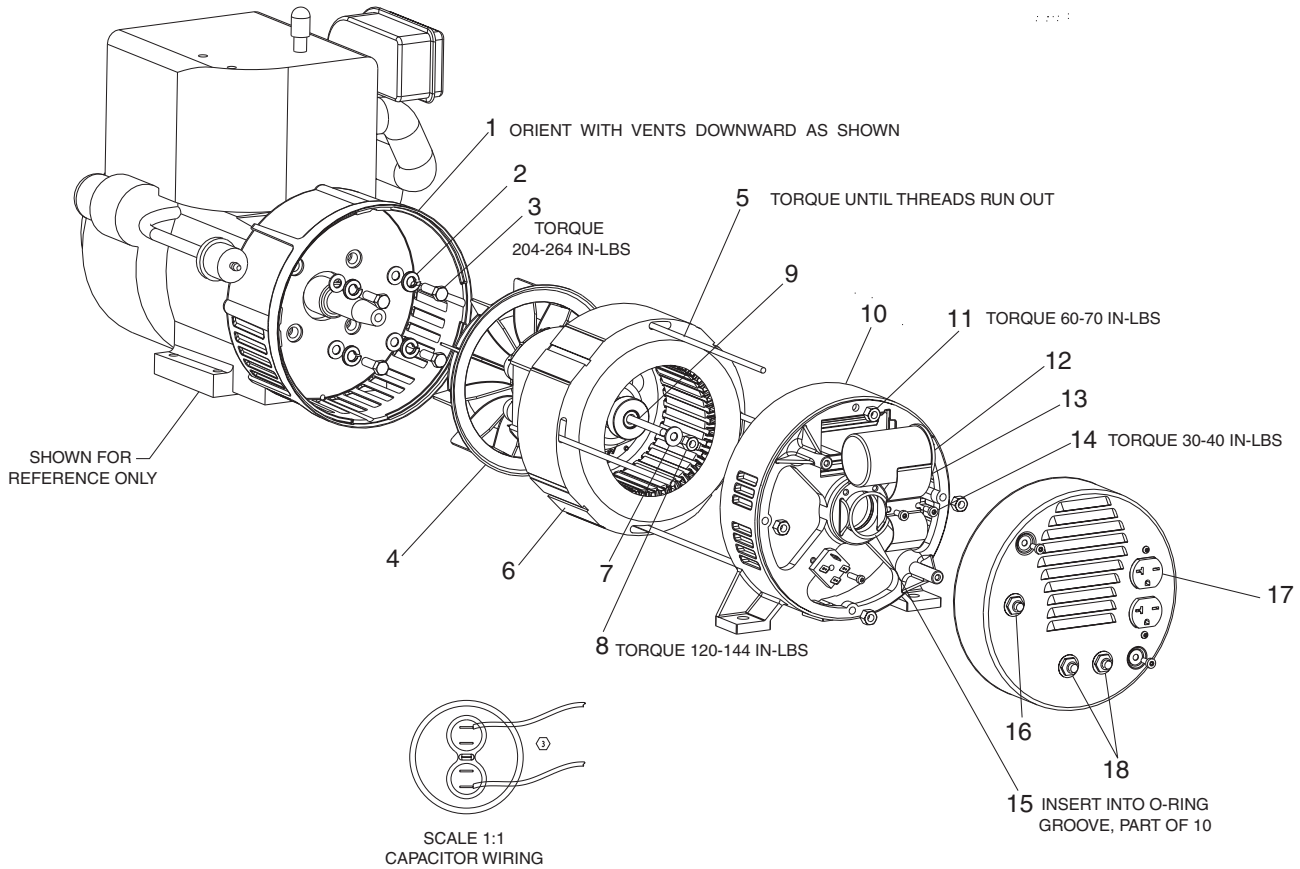

KEY NO.

KEY NO.	DESCRIPTION	PART NUMBER
1	DRIVE END ADAPTER	GS-0558
2	LOCK WASHER 3/8	SS-1503-CD
3	CAP SCREW 5/16 - 24X1	SSF-616-ZN
4	ROTOR ASSEMBLY	Z-D20261
5	STATOR THRU BOLT	GS-0415
6	STATOR ASSEMBLY	Z-D20264
7	WASHER 11/16OD x 11/32	SS-6506-CD
8	NUT 5/16-24	SSF-576
9	ROTOR THRU BOLT	GS-0661-1
10	BEARING SUPPORT	Z-GS-0861
11	HEX NUT 1/4-20	SSF-575
12	CAPACITOR	GS-0873
13	CAPACITOR BRACKET	GS-0595
14	SCREW 10 - 24 x 9/16	SSF-553-1
15	O-RING	GS-0862
16	CIRCUIT BREAKER 25A	Z-GS-0645
17	RECEPTACLE 120V DUPLEX	GS-0019
18	CIRCUIT BREAKER 20A	Z-GS-0025