

CGTP3000

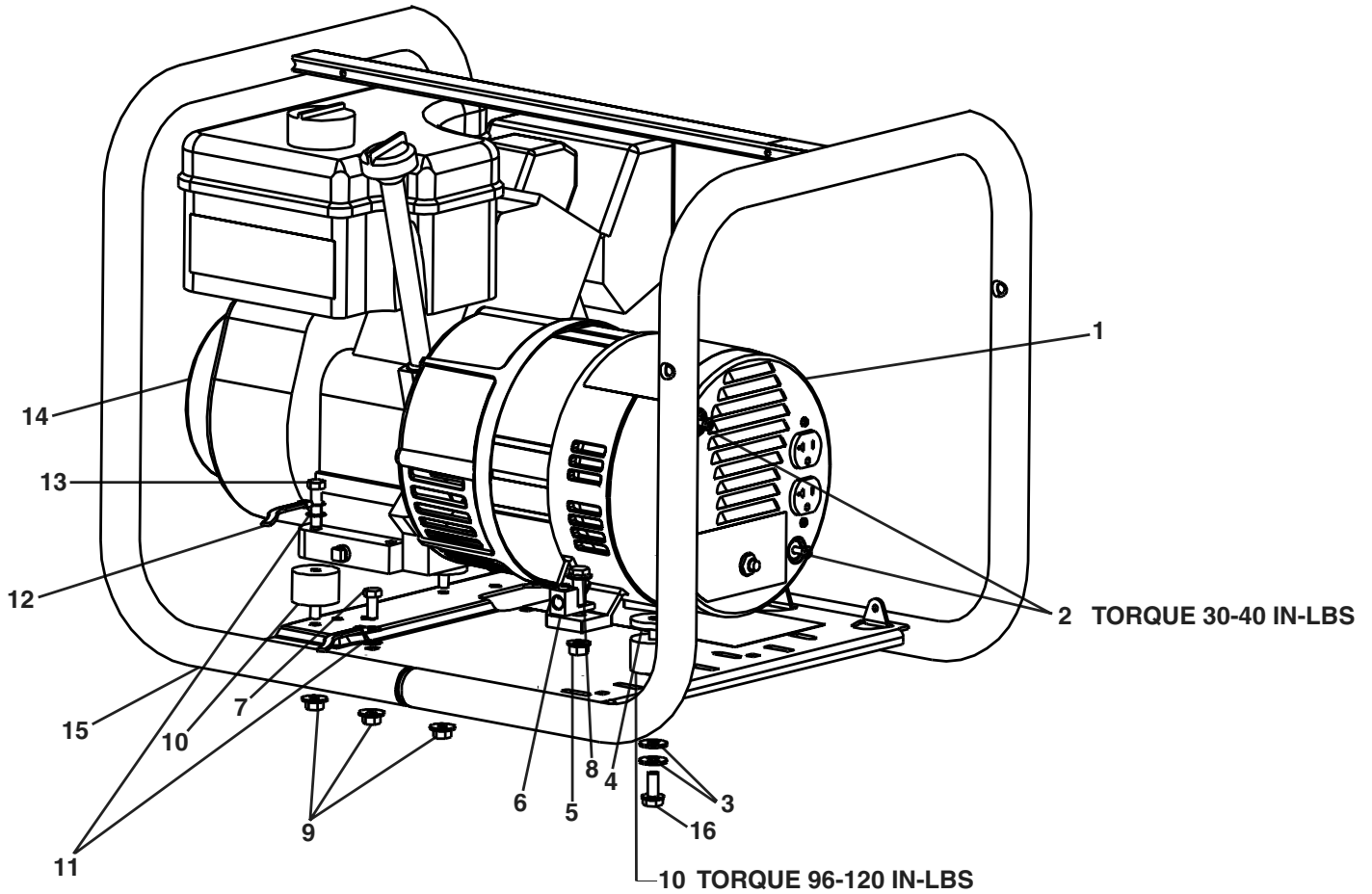

KEY NO.

KEY NO.	DESCRIPTION	PART NUMBER
1	ENDCOVER	GS-0653
2	SCREW #10-24 x 1	SSF-553-1
3	WASHER, .875 OD .375 ID	SSN-632
4	WASHER 3/8	SSN-1014-ZN
5	LOCK NUT 3/8-16	SSF-8111-ZN
6	GROUND LUG	GS-0117
7	SCREW 5/16-18 x 3/4	SS-12-CD
8	SCREW 3/8-16 x 1	SSF-3140-ZN
9	LOCK NUT 5/16-18	SSF-8150
10	ISOLATORS	GS-0033
11	LOCK WASHER	SSN-1619-ZN
12	GROUND STRAP	GS-0118
13	SCREW, CAP 5/16-18 x 1.25	SSF-605
14	ENGINE (model#OHH60-71129C)	-
15	FRAME ASSEMBLY	GS-0615
16	SCREW 5/16-18 X 3/4	SSF-3152

Not Shown

MG-GENMAN-F	Operators Manual
GEN-CGTP3000	Parts Manual
GS-0660	Engine Manual

CGTP3000 (cont'd)

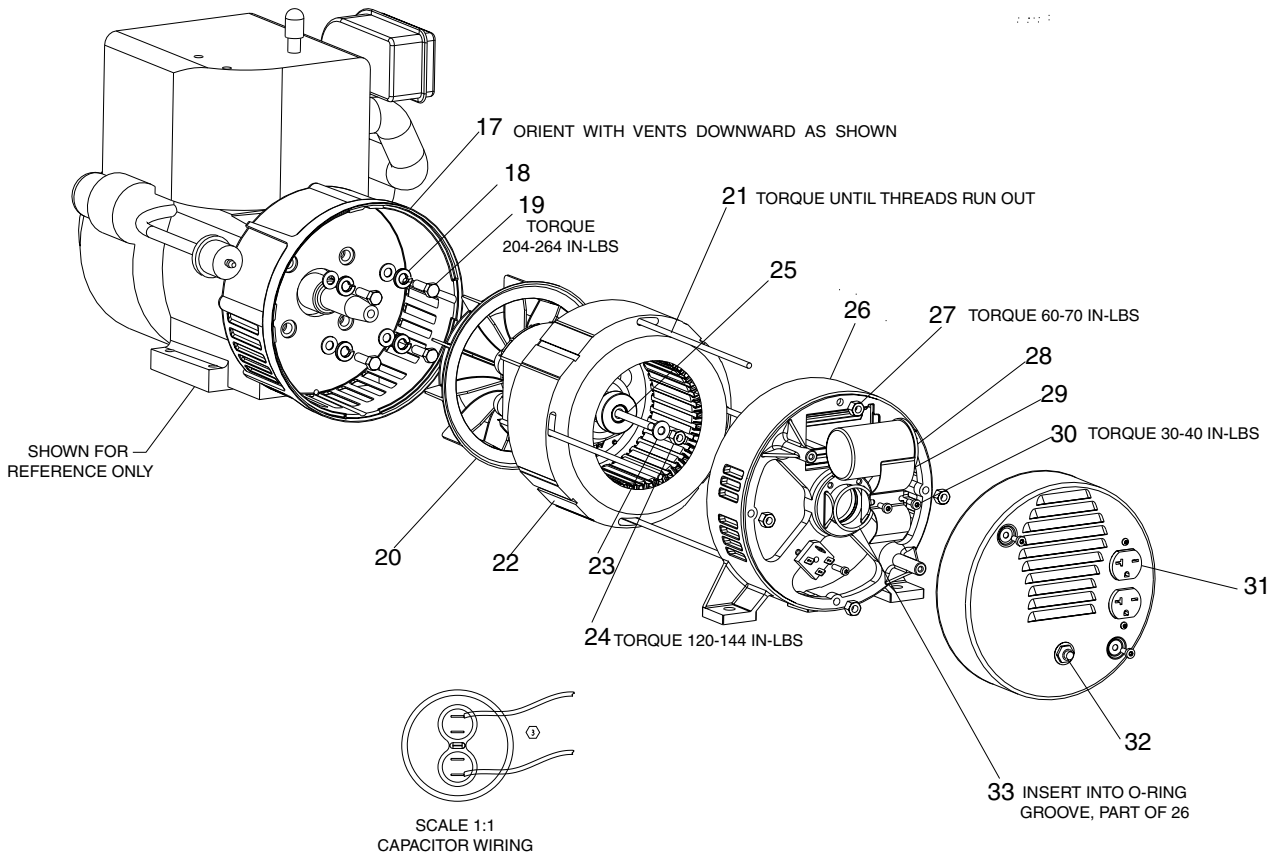

KEY

NO.	DESCRIPTION	PART NUMBER
17	DRIVE END ADAPTER	GS-0558
18	LOCK WASHER	SS-1503-CD
19	CAP SCREW 5/16-24x1	SSF-616-ZN
20	ROTOR ASSEMBLY	GS-0658
21	STATOR THRU BOLT	GS-0415
22	STATOR ASSEMBLY	GS-0657
23	WASHER 11/16 OD x 11/32	SS-6506-CD
24	NUT 5/16-24	SSF-576
25	ROTOR THRU BOLT	GS-0661
26	BEARING SUPPORT	GS-0861
27	HEX NUT 1/4-20	SSF-575
28	CAPACITOR	GS-0592
29	CAPACITOR BRACKET	GS-0595
30	SCREW 10-24X9/16	SSF-553-1
31	120V DUPL. RECEPTACLE (20A)	GS-0019
32	CIRCUIT BREAKER(25A)	GS-0645
33	O-RING	GS-0862

ITEM NOT SHOWN

*DIODE(S) GS-0082

*Refer to Page 4 in the Generator Repair Section for further **diode** information.