

# GHV4500

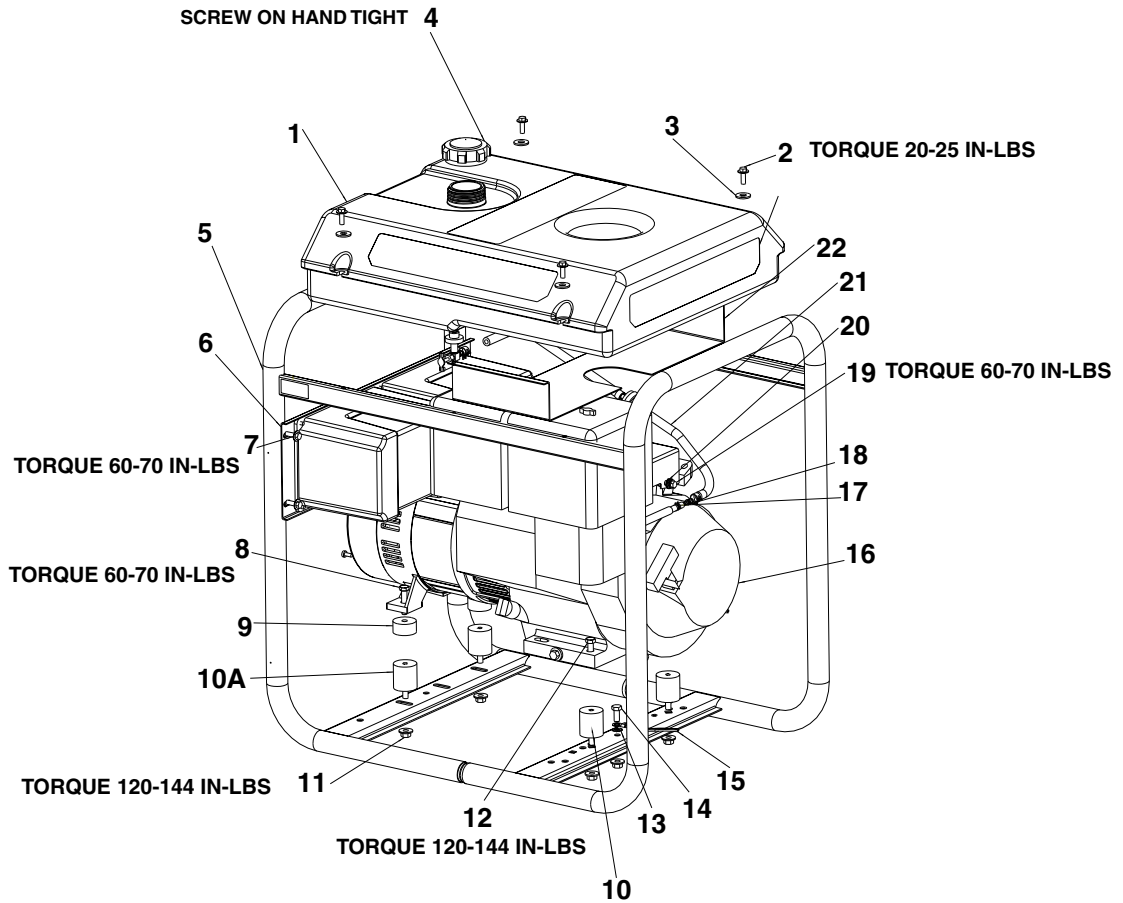

**KEY  
NO.**

**DESCRIPTION**

**PART NUMBER**

KEY NO.	DESCRIPTION	PART NUMBER
1	FUEL TANK	GS-0795
2	FUEL TANK SCREWS	91895680
3	WASHER	SSN-632
4	FUEL CAP	GS-0443
5	FRAME ASSEMBLY	GS-0522
6	PANEL ASSEMBLY	GS-0524
7	SCREW 1/4-20 x 3/4	91895680
8	SCREW 5/16-18UNC	95829230
9	SPACER 5/16	GS-0492
10	ISOLATOR	GS-0033
10A	ISOLATOR	GS-0433
11	LOCK NUT 5/16-18	SSF-8150
12	SCREW 5/16-18 x 1	SSF-605
13	LOCK WASHER	SSN-1619-ZN
14	SCREW 5/16-18 x 3/4	SS-12-CD
15	GROUND STRAP	GS-0118
16	ENGINE (model # GX270VWN2)	-
17	HOSE CLAMP .301 ID	GS-0560
18	UNION 1/4 TO 3/8	GS-0535
19	SCREW 1/4 x 5/8	39124607
20	LOCK WASHER	SS-1503-CD
21	FUEL HOSE	GS-0225
22	HEAT SHIELD	GS-0432

## GHV4500 (cont'd)

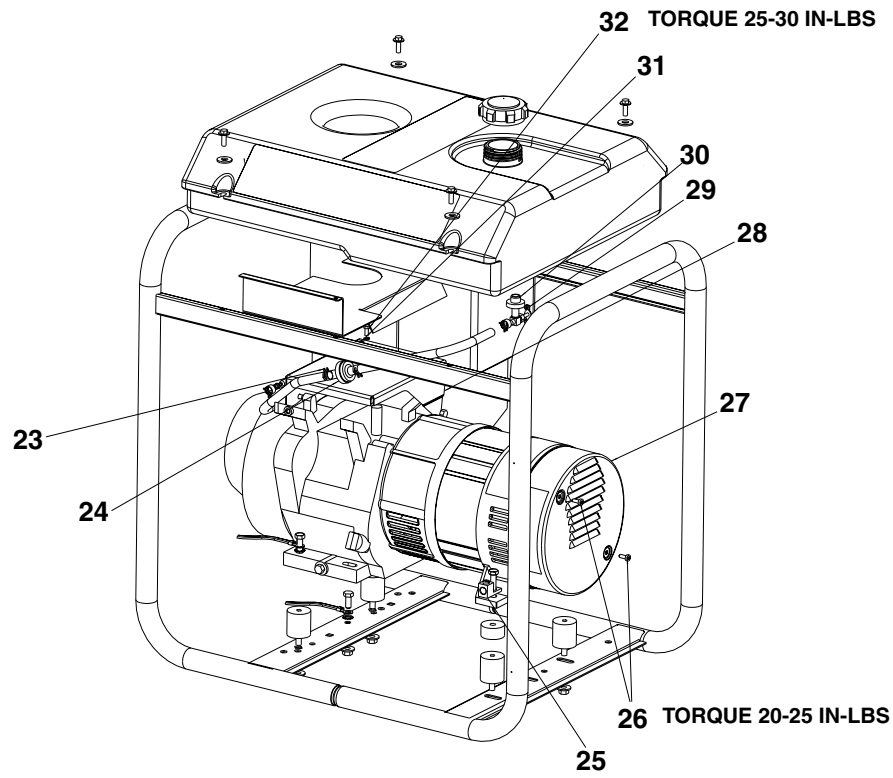

<b>KEY NO.</b>	<b>DESCRIPTION</b>	<b>PART NUMBER</b>
23	FUEL CLAMP .50 ID	GS-0227
24	FUEL FILTER	GS-0459
25	GROUND LUG	GS-0117
26	SCREW 10-24 x 9/16	SSF-553
27	END COVER	GS-0077
28	ENGINE COVER	GS-0540
29	DRAINCOCK	GS-0437
30	DRAINCOCK GROMMET	GS-0446
31	LOCK WASHER #10	SSN-626
32	SCREW M5 x 12HHCS	SSF-627

## GHV4500 (cont'd)

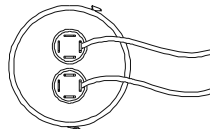
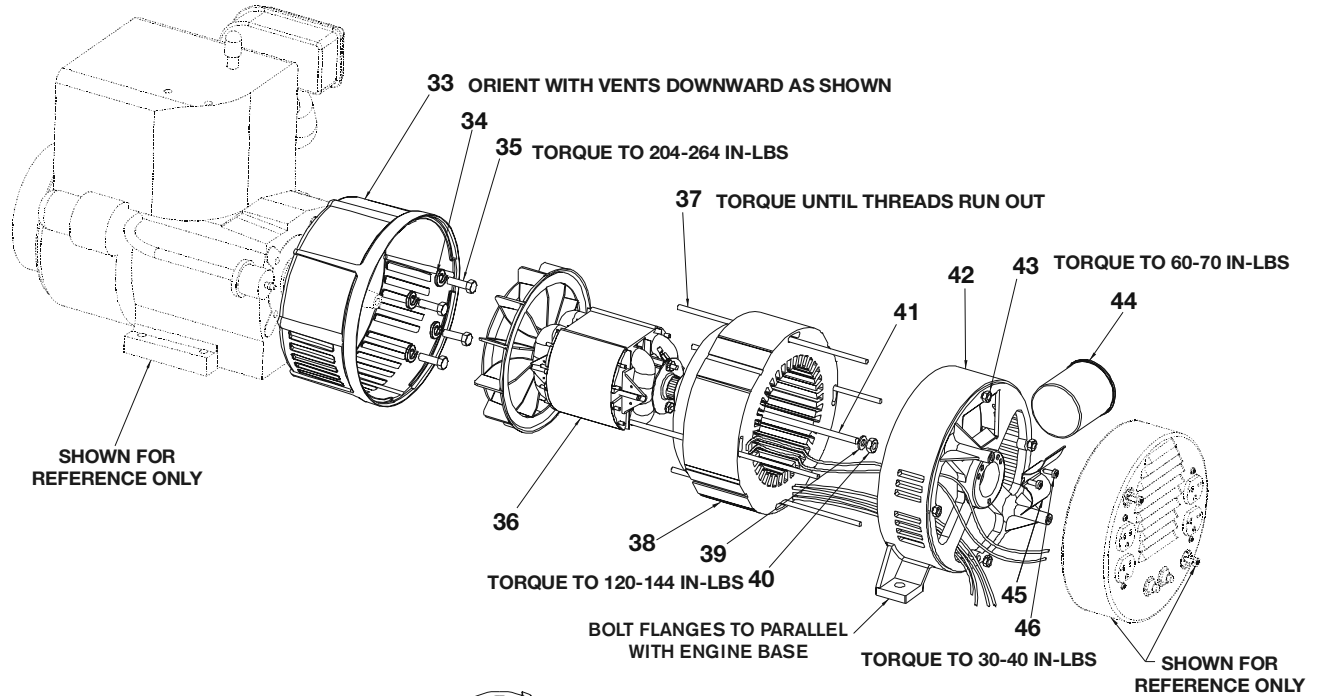

CAPACITOR WIRING  
SCALE 1:1

KEY NO.	DESCRIPTION	PART NUMBER
33	DRIVE END ADAPTER	GS-0076
34	LOCK WASHER 3/8	SSN-619
35	CAP SCREW 3/8-16 x 1	SSF-577
36	ROTOR ASSEMBLY	GS-0478
37	STATOR THRU BOLT	GS-0110
38	STATOR ASSEMBLY	GS-0100-1
39	WASHER 11/16OD x 11/32	SS-6506-CD
40	NUT 5/16-24	SSF-576
41	ROTOR THRU BOLT	GS-0091-1
42	BEARING SUPPORT	GS-0681
43	HEX NUT 1/4-20	SSF-575
44	CAPACITOR	GS-0104
45	CAPACITOR BRACKET	GS-0487
46	SCREW 10-32	SSF-553
<b><u>ITEM NOT SHOWN</u></b>		
	*DIODES	GS-0082
	O-RING (included in GS-0861)	GS-0862

\*Refer to Page 4 in the Generator Repair Section for further **diode** information.

## GHV4500 (cont'd)

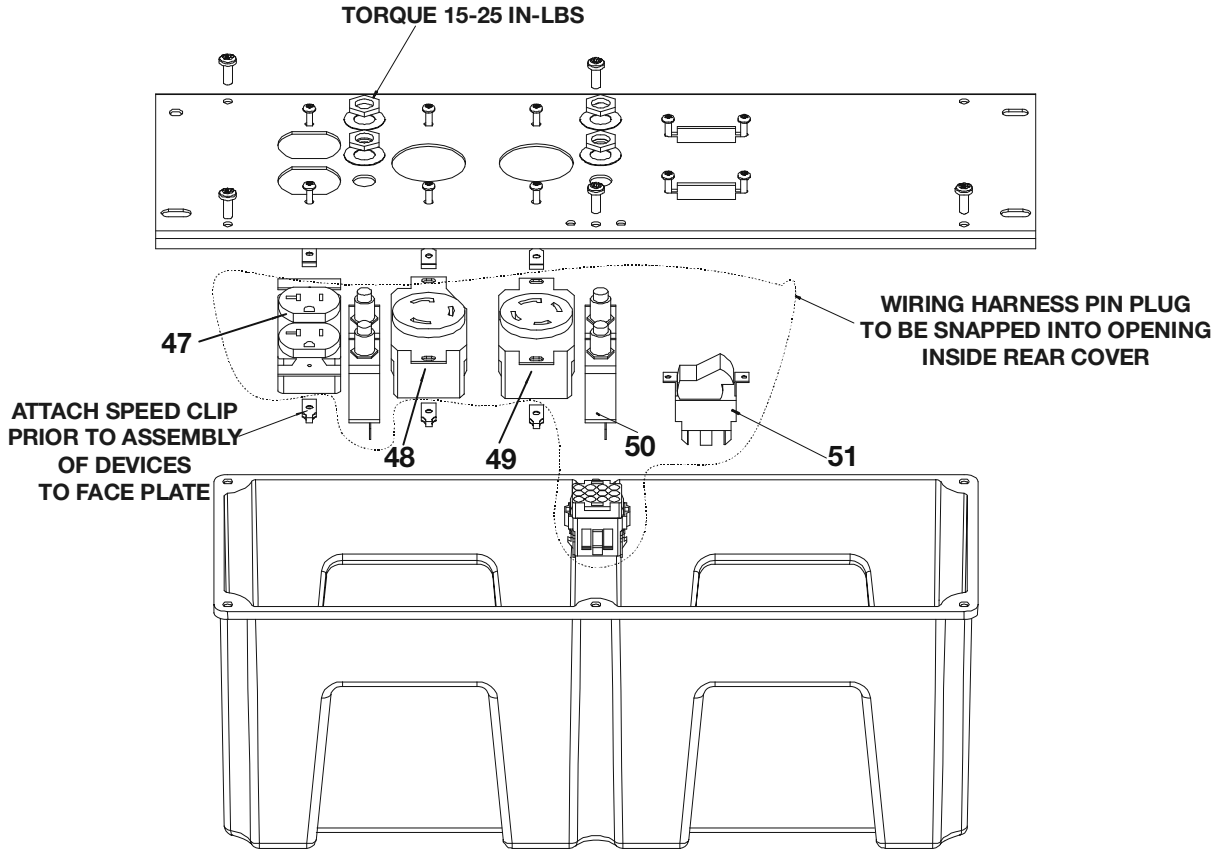

KEY NO.	DESCRIPTION	PART NUMBER
47	120V DUPL. RECEPTACLE	GS-0019
48	3 PRONG TWISTLOCK	GS-0480
49	4 PRONG TWISTLOCK	GS-0445
50	CIRCUIT BREAKER	GS-0024
51	FULL POWER SWITCH	GS-0045

***Not Shown***

MG-GENMAN-F	Operators Manual
GEN-HV4500	Parts Manual
GS-0525	Engine Manual