

# 100E3D-1 C100E3D-1

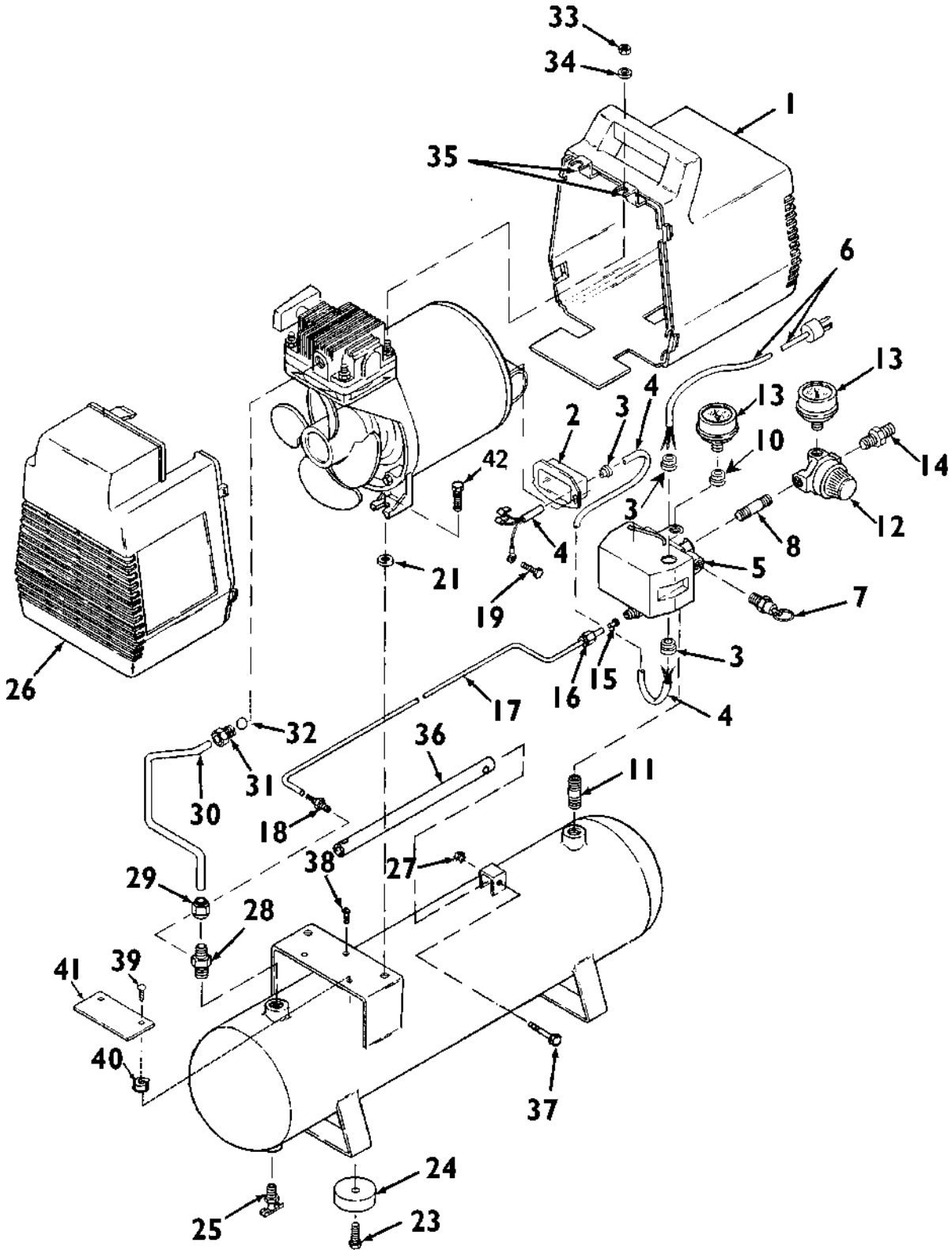

# 100E3D-1

## C100E3D-1 (cont'd)

<b>KEY NO.</b>	<b>PART NUMBER</b>	<b>DESCRIPTION</b>
1	DAC-488-2 or DAC-486	Rear Shroud Assembly (includes two #35)
2	CAC-1423	Terminal Box Cover
3	SSW-7367	Strain Relief (3 used)
4	SUDL-402-2	Cord Assembly - Motor
5	CAC-4332-2	Pressure Switch Assembly
6	SUDL-403-1	Cord Assembly - Line
7	TIA-4150	Safety Valve
8	SS-1286	Nipple (1/4" NPT X 7/8" long)
10	SSP-6021	Bushing, Reducer (1/8-1/4" NPT)
11	SS-2071	Nipple (1/4" NPT X 1 1/2" long)
12	CAC-4296-1	Regulator
13	GA-369	Pressure Gauge (2 used)
14	H-2099	Adapter
15	SSP-9013	Tube Insert
16	SSP-7813	Nut/Sleeve Assy. (for 3/8" O.D. tube)
17	CAC-1245-1	Pressure Relief Tube
18	SSP-6088	Barbed Fitting
19	SUDL-9-1	Ground Screw
21	SSW-7462	Spacer
23	SSF-607	Screw (4 used) (torque snug)
24	SST-5314-1	Rubber Foot (4 used)
25	SS-2707	Drain Valve
26	AC-0077	Front Shroud
27	SSF-8150	Locknut (5/16-18)
28	CAC-4290-3	Check Valve
29	SSP-7813	Nut Sleeve Assembly (for 3/8" O.D. Tube)
30	AC-0127	Outlet Tube
31	SSP-7821-1	Nut (tighten to 100-120 in.lbs.)
32	SSG-3105	O-ring
33	SS-655-ZN	Locknut (2 used) (torque to 50-60 in. lbs.)
34	SSN-60-ZN	Washer (2 used)
35	CAC-1121	Bracket (2 used)
36	CAC-1267	Saddle Brace
37	SSF-999-1	Handle Screw (5/16-18 X 1 3/4")
38	SSF-1000	Screw 12-14 x 3/4
39	SSF-1000	Screw 12-14 x 3/4
40	SSN-62	Nylon Spacer
41	DAC-115-1	Plate
42	SSF-928	Screw (2 used) (torque to 90-100 in. lbs.)

# 100E3D-1 C100E3D-1 (cont'd)

KEY NO.	TORQUE
55	7 to 10 Ft. Lbs.
56	7 to 10 Ft. Lbs.
66	100 to 120 In. Lbs.
69	80 to 100 In. Lbs.
◆	42 to 48 In. Lbs.

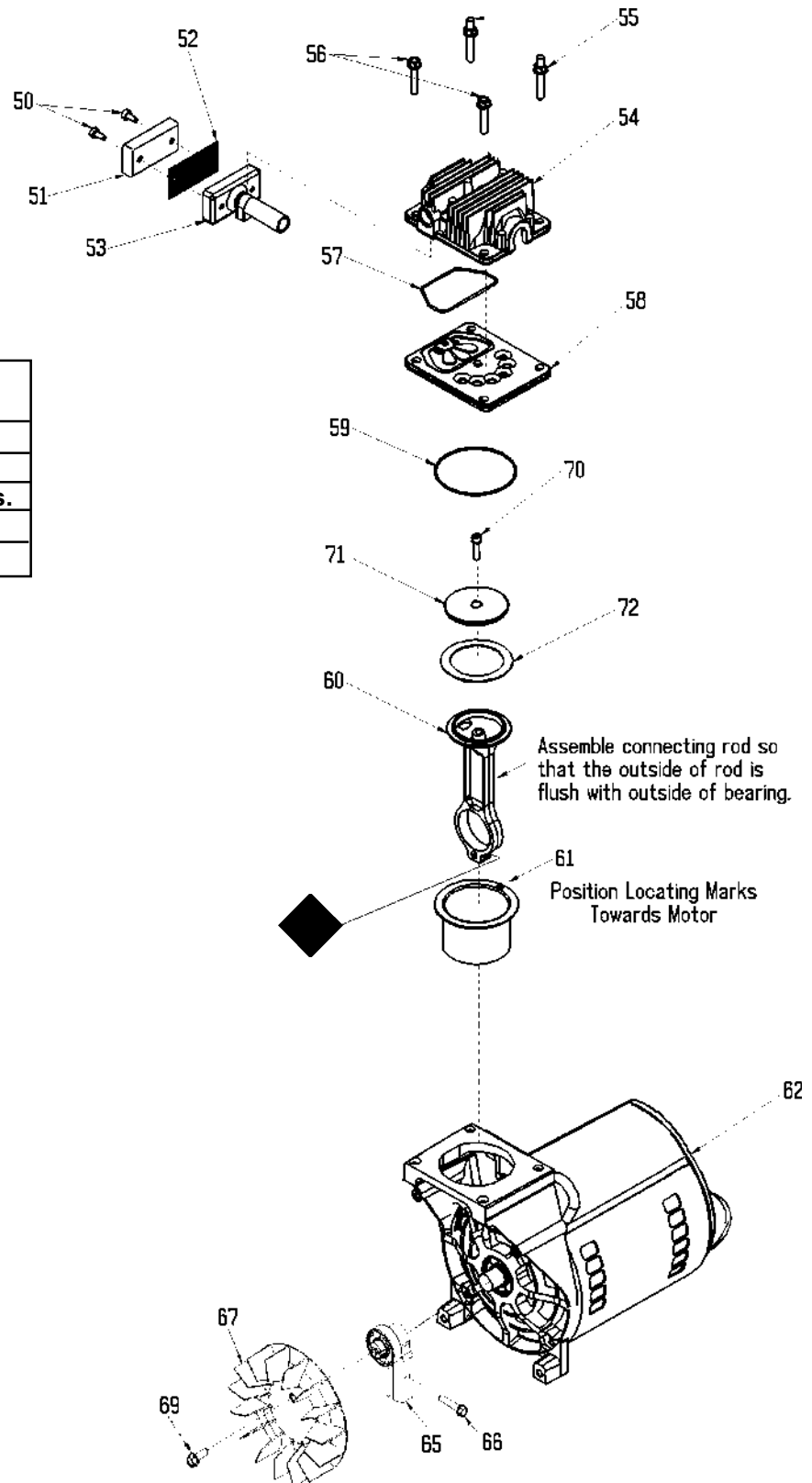

# 100E3D-1

## C100E3D-1 (cont'd)

<b>KEY</b>	<b><u>NO.</u></b>	<b><u>PART NUMBER</u></b>	<b><u>DESCRIPTION</u></b>
+	50	---	Air filter fastener (2 used)
	51	DAC-143	Air filter
+	52	---	Muffler screen
+	53	---	Intake muffler
	54	AC-0037	Head
	55	SSF-589	Stud 1/4"-20 x 1 1/4"
	56	SSF-927	Screw 1/4-20 x 1 1/4"
* ✓	57	ACG-45	O-Ring
	58	AC-0032	Valve plate assembly (includes valves, restrictors & screws)
* ✓	59	SSG-8156	O-ring
*	60	---	Connecting rod assembly
* ✓	61	---	Cylinder sleeve (position locating mark toward motor)
	62	M0-3025-2	Motor
	65	AC-0140	Eccentric Flywheel Bearing Assy.
	66	SSF-615	Screw 1/4-20 unc-2A
	67	AC-0108	Fan
	69	SSF-586	Screw 1/4-20 unc x .75
* ✓	70	SSF-3158-1	Screw 10-24 X .75 T25 Torx
*	71	---	Compression Ring Connecting Rod Cap
* ✓	72	---	Compression Ring

**NOT ILLUSTRATED**

KK-4315	Pressure Relief Valve
MG2-OFTANK-4A	Owners Manual (100E3D-1 & C100E3D-1)
MP2-1003D-1	Parts Manual (100E3D-1 & C100E3D-1)

- + Keys 50, 52 and 53 can only be purchased as part of KK-4977 (also includes Key #51).
- \* Keys 57, 59, 60, 61, 70, 71, and 72 are purchased as part of KK-4835 piston/cylinder kit.
- ✓ Keys 57, 59, 61, 70 and 72 can be purchased as part of K-0058 cylinder sleeve/compression ring kit.