

150E4D-2 C150E4D-2

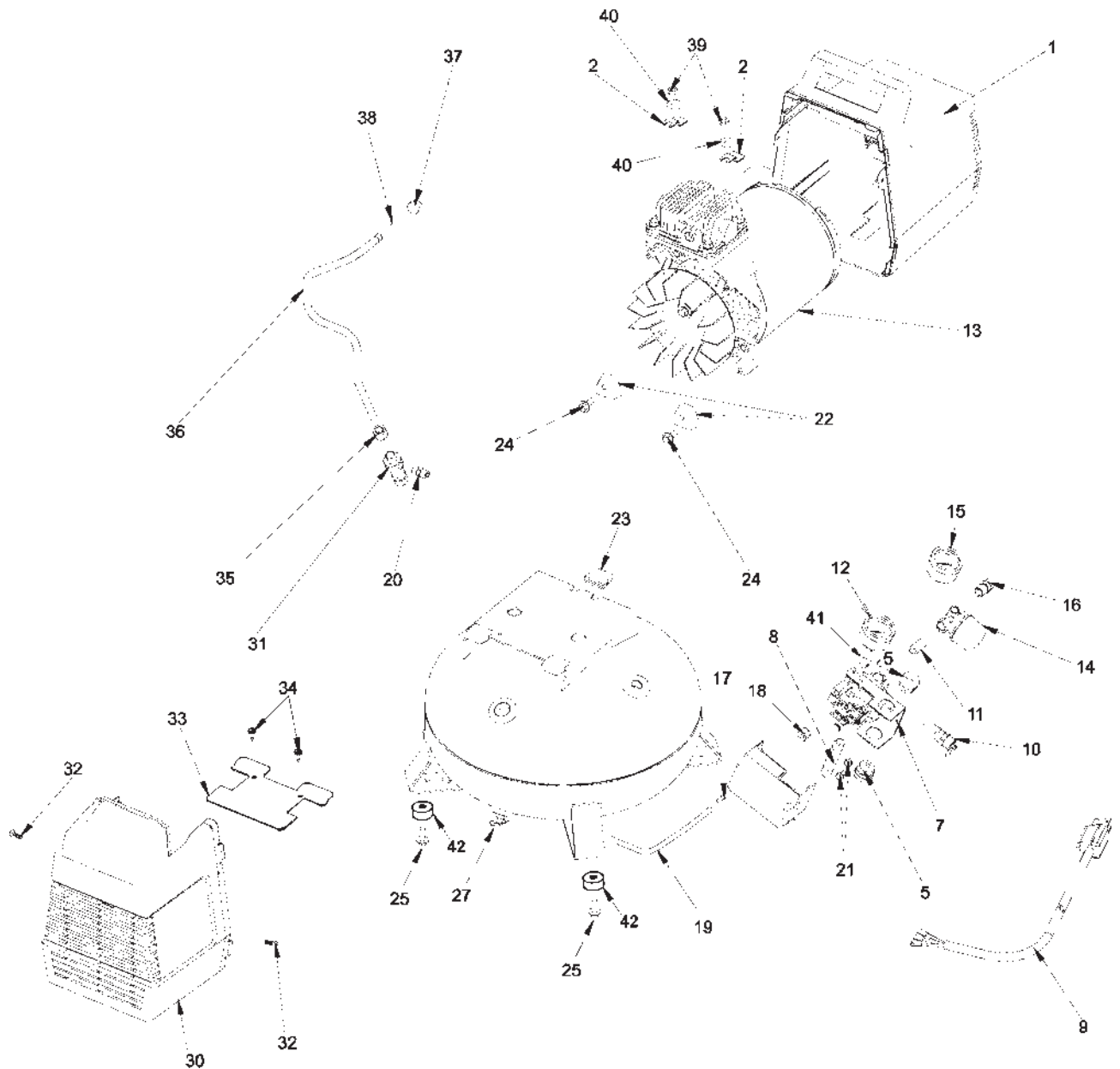

150E4D-2

C150E4D-2

KEY		
<u>NO.</u>	<u>PART NUMBER</u>	<u>DESCRIPTION</u>
1	AC-0402	Rear shroud assembly
2	CAC-1121	Bracket (2 used)
5	SSW-7367	Strain relief (2 used)
7	AC-0439-1	Pressure switch/manifold
8	SSP-480	Nipple
9	SUDL-403-1	Power cord assembly
10	TIA-4150	Safety valve
11	SS-1286	Nipple
12	GA-369	Gauge
13	-----	-----
14	CAC-4296-1	Regulator
15	GA-369	Gauge
16	H-2099	Adapter
17	SSP-9013	Tube insert
18	SSP-7811	Nut sleeve assembly (1/4")
19	CAC-1085-1	Pressure relief tube
20	SSP-6088	Barbed fitting
21	SUDL-9-1	Ground screw (2 used)
22	ACG-18	Cup saddle mount (2 used)
23	ACG-19	Isolator (3 used)
24	91895680	Screw (2 used)
25	91895680	Screw (4 used)
27	SS-2707	Drain valve
30	AC-0401	Front shroud
31	AC-0631	Check valve assembly
32	SSF-3156	Screw (2 used)
33	AC-0397	Fan guard
34	SSF-953-ZN	Fan guard screw (2 used)
35	SSP-7813	Nut sleeve assembly (for 3/8" O.D. tube)
36	AC-0405	Outlet tube
37	SSP-7821-1	Nut
38	SSG-3105	O-Ring
39	SS-655-ZN	Locknut (2 used)
40	SSN-60-ZN	Washer (2 used)
41	SSP-6021	Bushing Reducer
42	SST-5314-1	Rubber Foot

150E4D-2 C150E4D-2

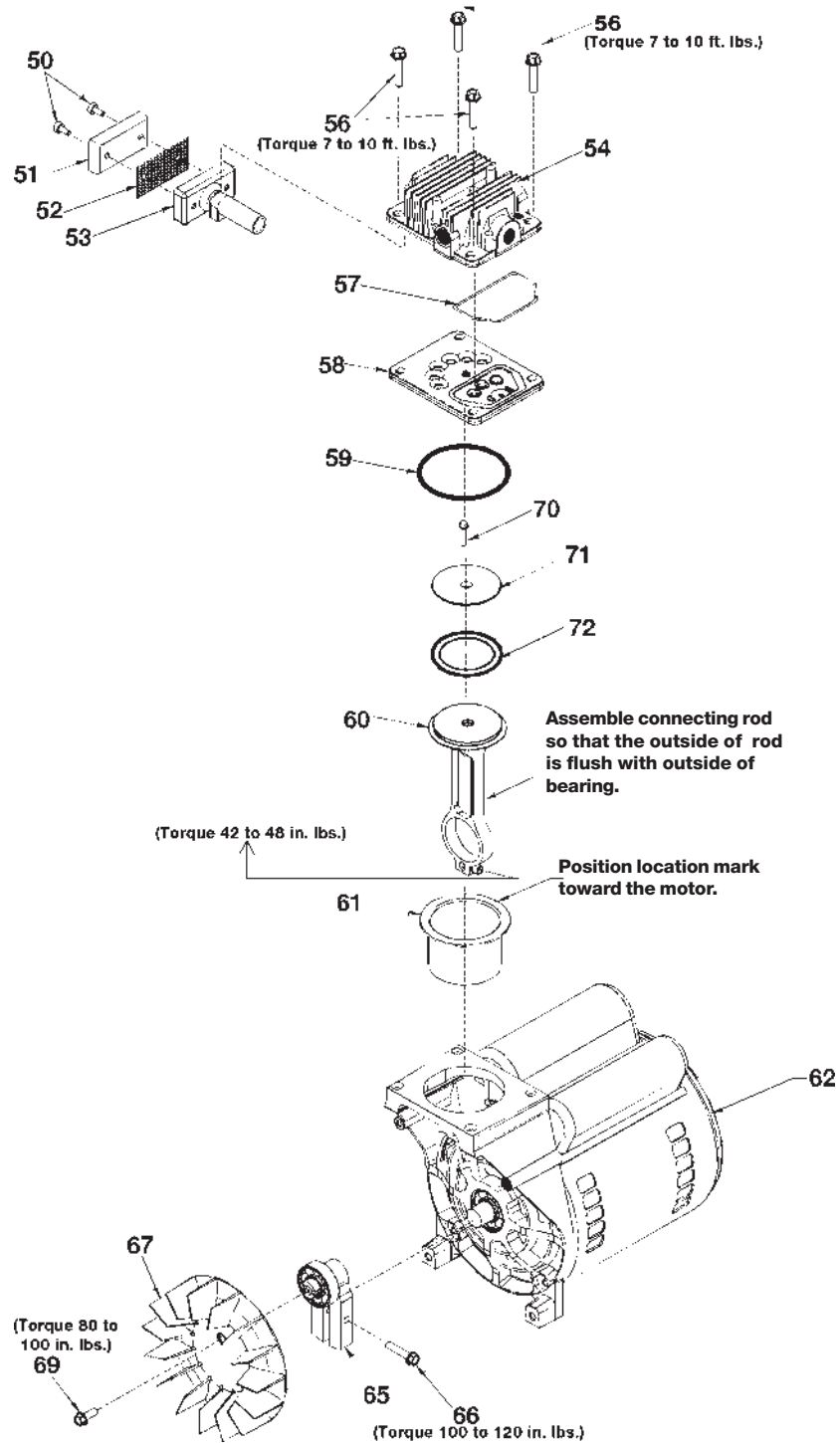

150E4D-2

C150E4D-2

KEY	NO.	PART NUMBER	DESCRIPTION
	+ 50	---	Air filter fastener (2 used)
	51	DAC-143	Air filter
	+ 52	---	Muffler screen
	+ 53	---	Intake muffler
	54	AC-0037	Head
	56	SSF-927	Screw 1/4-20 x 1 1/4" (4 used)
*	✓ 57	ACG-45	O-Ring
	58	AC-0032	Valve plate assembly (includes valves, restrictors & screws)
*	✓ 59	SSG-8156	O-ring
*	60	---	Connecting rod assembly
*	✓ 61	---	Cylinder sleeve (position locating mark toward motor)
	62	MO-9047-1	Motor
	65	AC-0140	Eccentric Flywheel Bearing Assy.
	66	SSF-615	Screw (1/4-20 unc-2A)
	67	AC-0108	Fan
	69	SSF-586	Screw (1/4-20 unc x .75)
*	✓ 70	SSF-3158-1	Screw 10-24 X .75 T25 Torx
*	71	---	Connecting Rod Cap
*	✓ 72	---	Compression Ring

NOT ILLUSTRATED

MG2-OFTANK-4A
MP2-150E4D-2B

Owners Manual
Parts Manual

- + Keys 50, 52 and 53 can only be purchased as part of KK-4977 (also includes Key #51).
- * Keys 57, 59, 60, 61, 70, 71, and 72 are purchased as part of KK-4835 piston/cylinder kit.
- ✓ Keys 57, 59, 61, 70 and 72 can be purchased as part of K-0058 cylinder sleeve/compression ring kit.