

250E14AD

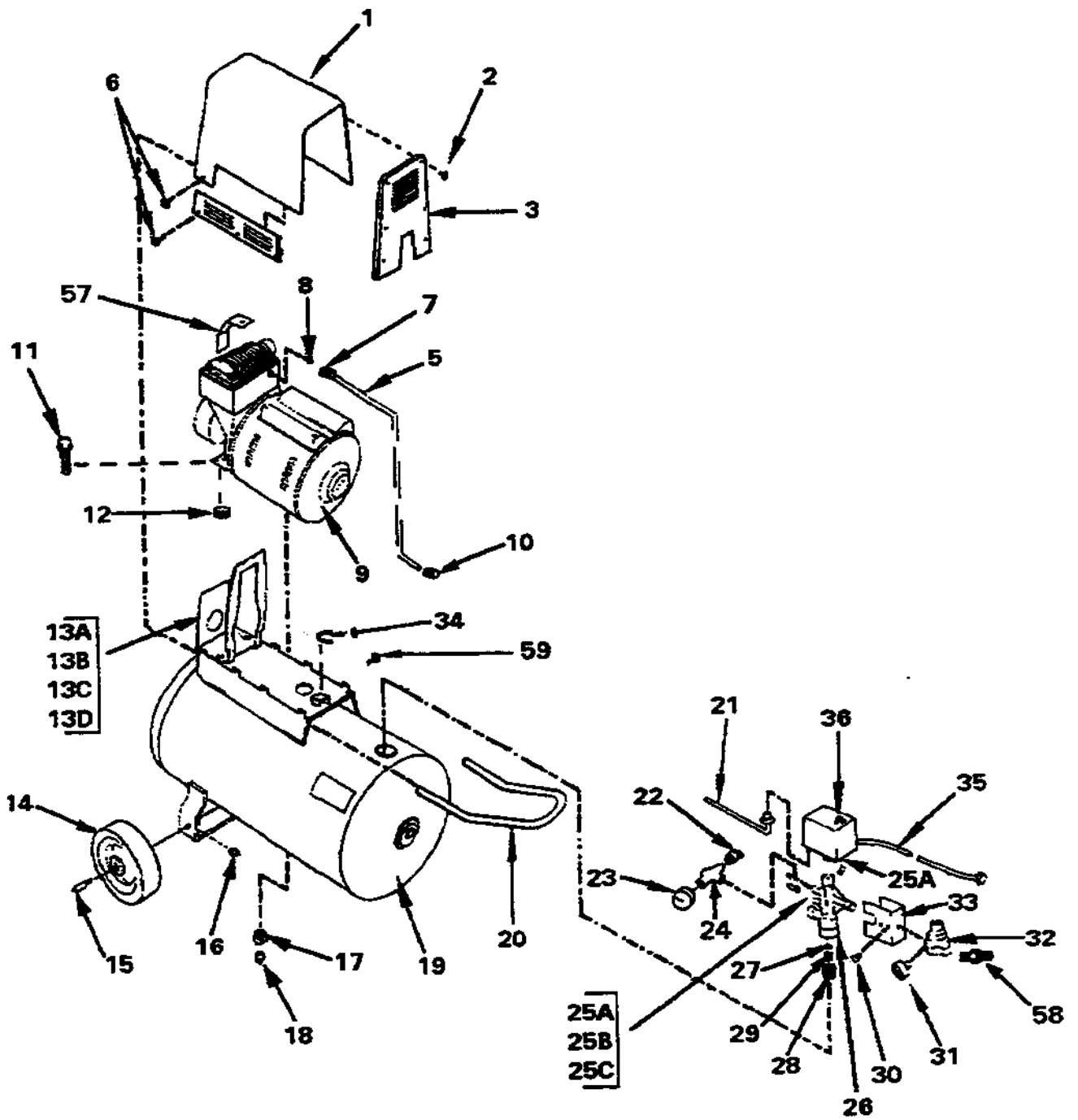

250E14AD (cont'd)

KEY NO.	PART NUMBER	DESCRIPTION
1	DAC-487	Shroud Assy. (includes #2, 3, 4)
2	91892588	Screw (12 used)
+ 3	---	Front Cover (included with #1)
+ 4	---	Side Cover (included with #1)
5	DAC-165	Outlet Tube
6	91895680	Screw (8 used) (torque 50-70 in/lb)
7	SSP-7821-1	Nut (torque 50-60 in/lb)
8	CAC-1120	Bracket
9	C-MO-3018-4	Motor 2 1/2 HP
10	SSP-7813	Silicone Sleeve
11	SSF-505	Nut (torque 100-120 in/lb)
12	CAC-1098	Isolator
13	CAC-1395	Baffle
14	CAC-4293	Wheel (2 used)
15	CAC-60	Shoulder Bolt
16	SSF-8080-ZN	Hex Nut (2 used)
17	SSP-1138	Reducer Bushing
18	SS-2707	Bushing, Hex Reducer
19	TA-4227	Drain Valve
20	DAC-177	Handle
21	CAC-4205	Cord Assy. (motor to switch)
22	97503734	Safety Valve 150 PSIG
23	C-GA-345	Gauge
24	97182133	Tee (1/8 x 1/8 x 1/4)
25A	DAC-175	Pressure Relief Tube
25B	SSP-9013	Tubing Insert
25C	SSP-7811	Nut Sleeve Assy. (1/4")
26	DAC-172	Manifold
>27	----	Check Valve Poppet
>28	----	Check Valve Body
>29	----	Check Valve Spring
30	9189632	Screw
31	C-GA-345	Gauge (4 used)
32	DAC-180	Pressure Regulator
33	97511471	Manifold Cover
34	CAC-1099	U-Channel
35	SUDL-403-1	Cord Assy. (line)
36	DAC-181	Pressure Switch

- + Keys 3 and 4 can only be purchased as part of Key #1, DAC-487 Shroud Assy.
- > Keys 27, 28 and 29 can only be purchased as part of 97261176 Check Valve Kit.

250E14AD (cont'd)

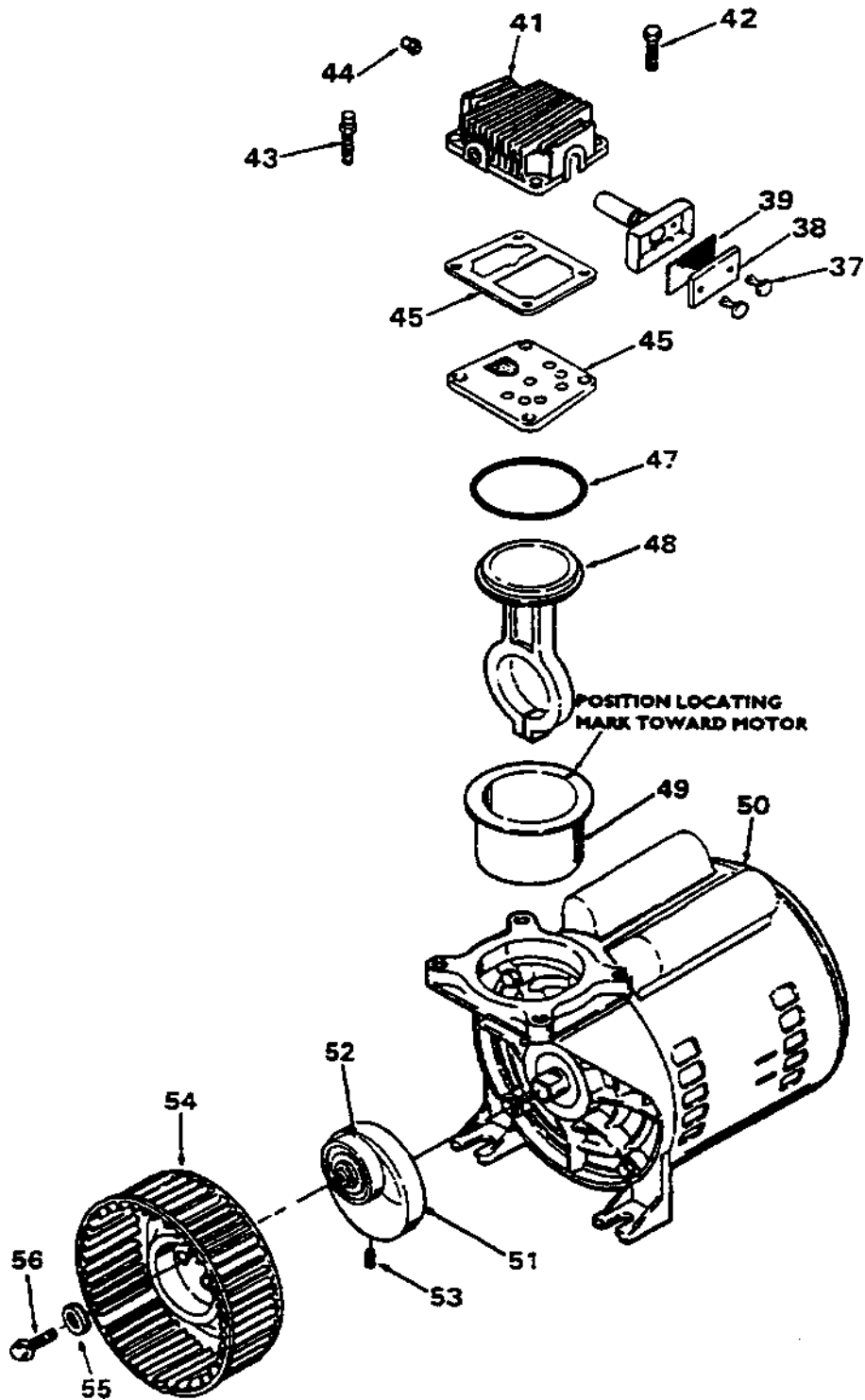

250E14AD (cont'd)

KEY NO.	PART NUMBER	DESCRIPTION
X 37	-----	Intake Filter Fastener
38	DAC-143	Intake Filter
X 39	-----	Filter Screen
X 40	-----	Intake Muffler
41	KK-4987	Head
42	SSF-6640	Stud
43	SSF-990	Screw (3 used)
44	DAC-140	Flow Valve
45	CAC-1175	Gasket
46	KK-5040	Valve Plate Assembly (includes valves, restrictors and screws)
• 47	SSG-8156	O-Ring
• 48	-----	Connecting Rod Assembly (torque screw 30-35 in. lbs.)
• 49	-----	Cylinder Sleeve (position locating mark toward motor)
50	C-M0-3020-1	Motor 3 1/2 HP
51	Z-CAC-4086	Eccentric/Bearing Assembly (includes 1 ea. #52)
52	-----	Bearing (can only be purchased as part of #51)
53	SSF-3153	Screw (eccentric, torque 50-60 in. lbs.)
* 54	KK-5018	Squirrel Cage Fan
* 55	SS-6505-CD	Washer
* 56	SSF-3101	Screw #10-24 x 3/8" Long (torque 30-35 in. lbs.)

NOT ILLUSTRATED

SSH-8	Air Chuck
H-5796	Air Hose Assy. (1/4" ID x 15')
MG2-OFTANK-4A	General Manual
MP2-250E14D-1	Parts Manual

X Keys 37, 39, and 40 can only be purchased as part of KK-4981 Intake Filter Kit (includes one #38).

• Keys 47, 48 and 49 can only be purchased as part of KK-4835 Connecting Rod Kit.

* Keys 54, 55 and 56 can only be purchased as part of KK-5018 Fan Kit.