

CPFAC2600P

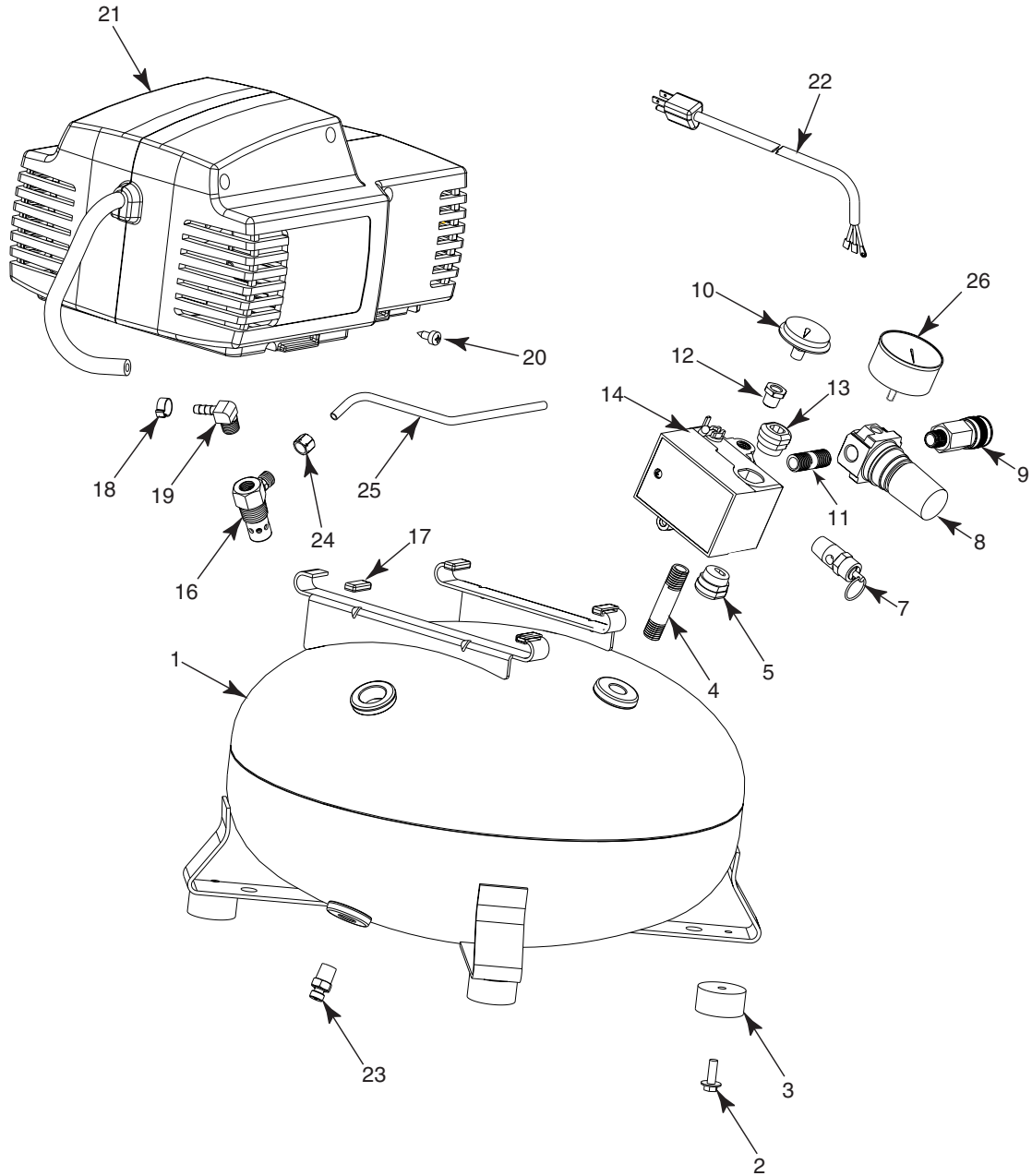

CPFAC2600P (cont'd)

Key

<u>No.</u>	<u>Part No.</u>	<u>Description</u>
1	TA-4497	Air Tank
2	91895680	Screw 1/4 - 20 x .75
3	SST-108	Rubber Bumper
4	SSP-480	Nipple 1/4-18 NPT x 2.50
5	SSW-7480	Strain Relief Bushing
7	D20114	Safety Valve
8	D20643	Regulator
9	D20675	Quick Connect 1/4 NPT
10	GA-366	Gauge
11	SS-2071	Nipple 1/4-18 NPT x 1.5
12	SSP-6021	Bushing Reducer 1/8-1/4NP
13	SSW-7367	Strain Relief Bushing
14	D20668	Pressure Switch
16	D20204	Check Valve
17	CAC-1254	Isolator Pump
18	CAC-1206-1	Hose Clamp
19	SSP-537	Elbow Hose
20	SSF-621	Screw 1/4 - 14 x .625
21	(See page 2)	Pump Assembly
22	AC-0539	Power Cord Assembly
23	AC-0430	Drain Valve
24	SSP-7811	Nut Sleeve Assembly 1/4"
25	D20831	Pressure Relief Tube
26	D20644	Gauge

Not Illustrated

- LA-3092-1 Label, Drain Tank Warning
- LA-3164 Label, Pressure Switch Warning
- LA-2828 Label, Hot Surface
- LA-2921 Label, English Warning
- LA-2901 Label, French/Spanish Warning

CPFAC2600P (cont'd)

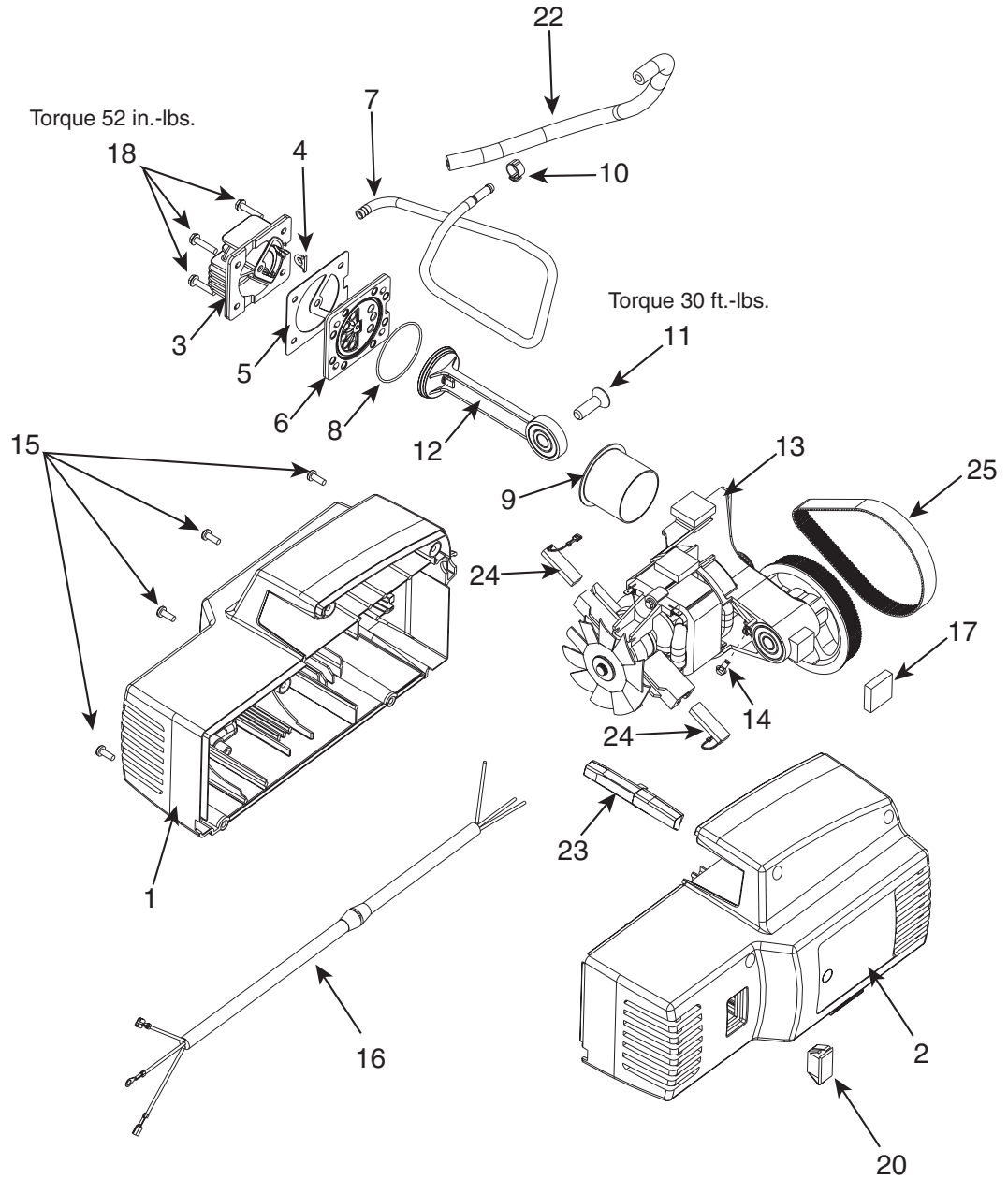

CPFAC2600P (cont'd)

Key

No.	Part No.	Description
1	D20671	Shroud - Left
2	D20672	Shroud - Right
3	CAC-1196	UMC Head
4	CAC-1212	Tube Seal
5	CAC-1199	Head Gasket
6	CAC-4323	Valve Plate Assembly
7	CAC-1194-1	Outlet Tube
8	SSG-8169	O-ring
9	CAC-1258	Cylinder Sleeve
10	CAC-1206-1	Hose Clamp
11	SSF-3147	Screw 3/8-16 UNC THD
12	CAC-4069	Rod Assembly
13	D20018	Endbell Assembly
14	SUDL-9-1	Screw 8-32 x .375/.344
15	SSF-3156	Screw 10-9 x .50
16	AC-0814	Motor Cord
17	CAC-1213	Isolator Washer
18	SSF-995	Screw 10-24 x 7/8
20	CAC-1283	Switch Cover
22	H-7051	Hose 1/4"ID x 10"
23	D20492	Handle Support
24	D20041	Brush
25	AC-0815	Timing Belt

Not Illustrated

D20787	Operators Manual
D20788	Service Manual