

F18-1

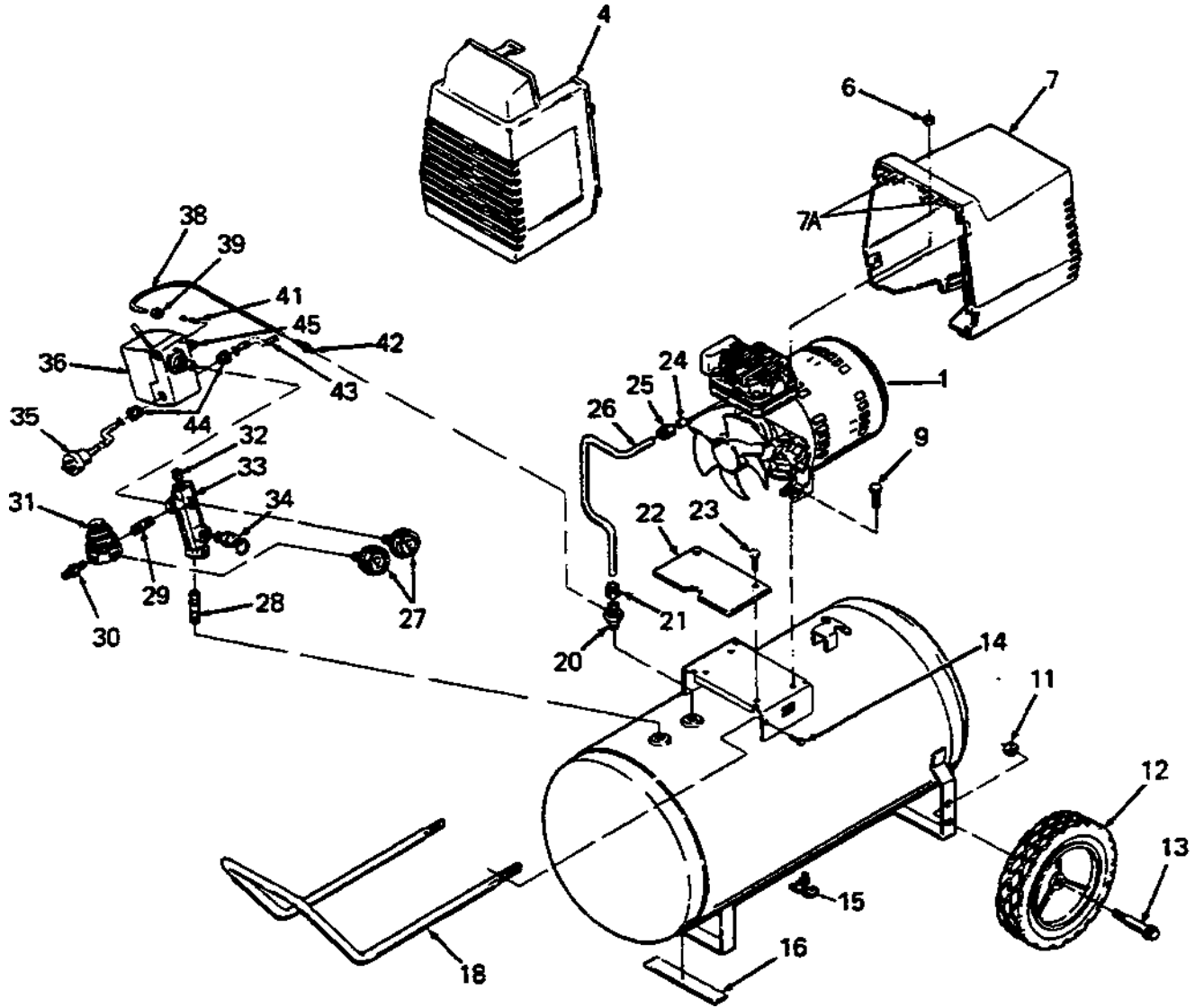

F18-1 (cont'd)

KEY NO.	PART NUMBER	DESCRIPTION
4	AC-0078	Shroud, Front
6	SS-655-ZN	Hex Nut 1/4" - 20 (2 used)
7	CAC-4300	Rear Shroud Assembly (includes 2 ea. #7A)
7A	CAC-1121	Shroud Bracket (2 used)
9	SSF-928	Screw (2 used)
11	SSF-8080-ZN	Nut 3/8"-16 (2 used)
12	CAC-4299	Wheel (2 used)
13	CAC-60	Shoulder Bolt (2 used)
14	SSF-981	Sheet Metal Screw 1/4" x 3/4" long (2 used)
15	SS-2707	Drain Valve
16	SUDL-6-1	Rubber Foot Strip
18	CAC-1304-1	Ring, Panel Mounting
20	CAC-4290-3	Handle (black finish)
21	SSP-7813	Check Valve
22	AC-0155	Nut Sleeve Assembly (for 3/8 O.D. Tube)
23	SSN-8001	Shroud Plate
24	CAC-1120	Ratchet Fastener (2 used)
25	SSP-7821-1	Silicone Sleeve
26	CAC-1083-1	Outlet Tube
27	GA-369	Pressure Gauge (2 used)
28	SS-2072-1	Nipple (3/8 x 2.5" NPT x 1 1/2" long)
29	SS-2071	Nipple (1/4 x 2.5" NPT x 1 1/2" long)
30	H-2099	Adaptor
31	CAC-4296-1	Regulator
32	SS-3222-CD	Pipe Plug 1/4" NPT
33	CAC-365	Manifold
34	TIA-4125	Safety Valve
35	SUDL-403-1	Cord Assembly - Line
36	CAC-4220-2	Pressure Switch
38	CAC-1085-1	Pressure Relief Tube (warm tube before installing on #42)
39	SSP-7811	Nut/Sleeve Assembly (1/4")
41	SSP-9013	Tube Insert
42	SSP-6088	Barbed Fitting
43	CAC-4215-1	Cord Assembly - Motor
44	SSW-7367	Strain Relief (2 used)

F18-1 (cont'd)

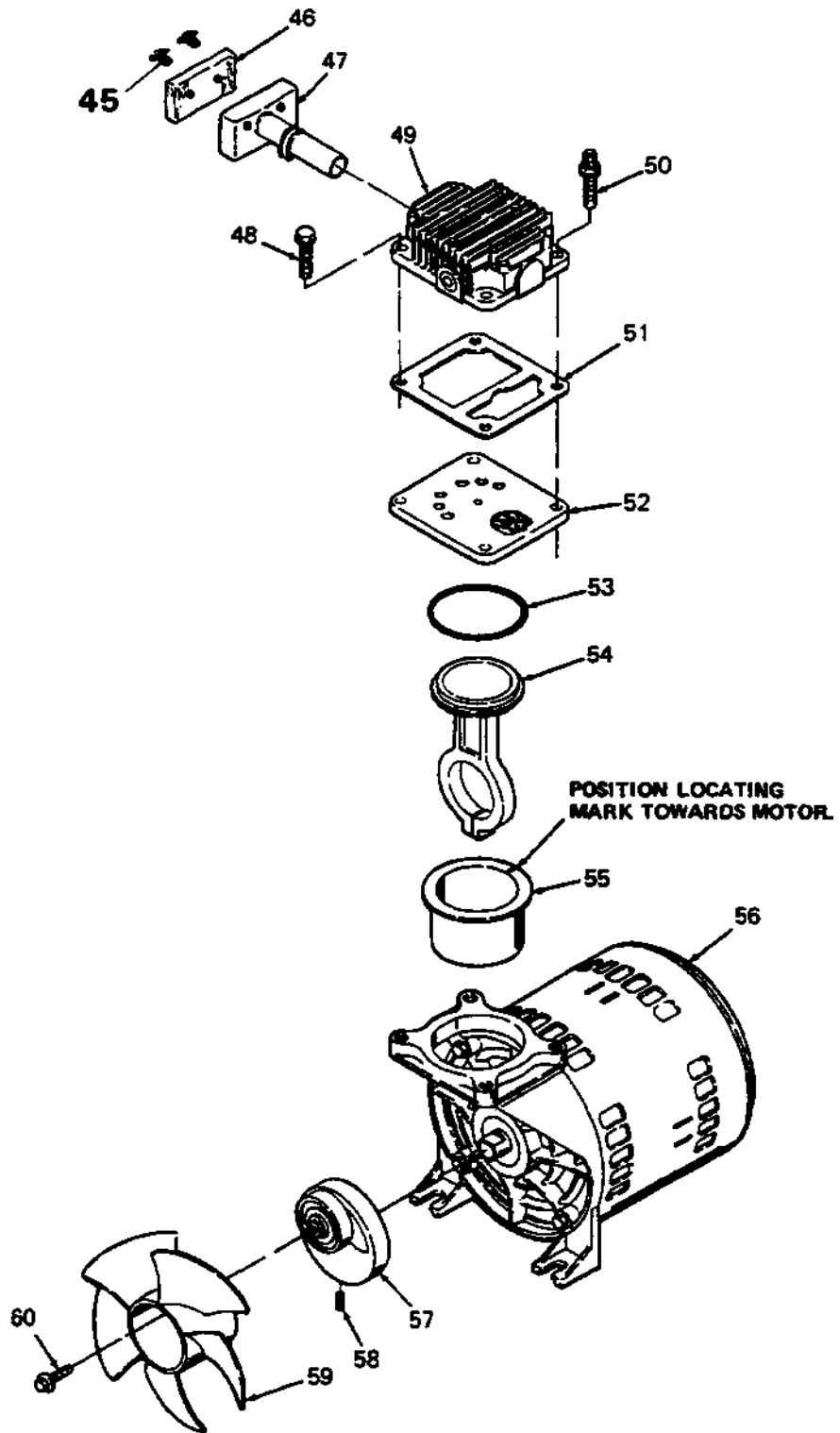

F18-1 (cont'd)

KEY	<u>PART NUMBER</u>	<u>DESCRIPTION</u>
+ 45	-----	Fastener, Filter
+ 46	DAC-143	Air Filter
+ 47	-----	Intake Muffler
48	SSF-990	Screw 1/4"-20 x 1 1/4" (6 used, torque 7-10 ft./lbs.)
49	KK-5040	Head
50	SSF-6640	Stud 1/4"-20 x 1 1/4" (2 used, torque 7-10 ft./lbs.)
51	CAC-1066	Gasket
52	KK-5040	Valve Plate Assembly (includes valves, restrictors & screws)
53	SSG-8156	O-ring
* 54	-----	Connecting Rod Assembly (torque screw 30-35 in./lbs.)
* 55	-----	Cylinder Sleeve (position locating mark towards motor)
56	Z-MO-3025-2	Motor 1 HP
57	Z-CAC-4306-2	Eccentric Bearing Assy.
58	SSF-2043	Screw (eccentric/flywheel, torque 50-60 in./lbs.)
59	CAC-1055-1	Fan
60	SSF-3101	Screw 1/4-28 UNF long (torque 30-35 in./lbs.)

NOT ILLUSTRATED

H-5796	Air Hose Assembly (1/4" I.D. x 15')
SSH-8	Air Chuck
SS-2707	Drain Valve
MG2-OFTANK-4A	Owners Manual
MP2-F18-2	Parts Manual

- * Keys 54& 55 can only be purchased as part of KK-4835 connecting rod kit.
- + Keys 45, 46 and 47 can only be purchased as part of KK-4977.