

F18-4

KEY NO.	TORQUE
5	50 to 60 In. Lbs
30	100 to 120 In. Lbs
36	60 to 75 In. Lbs.

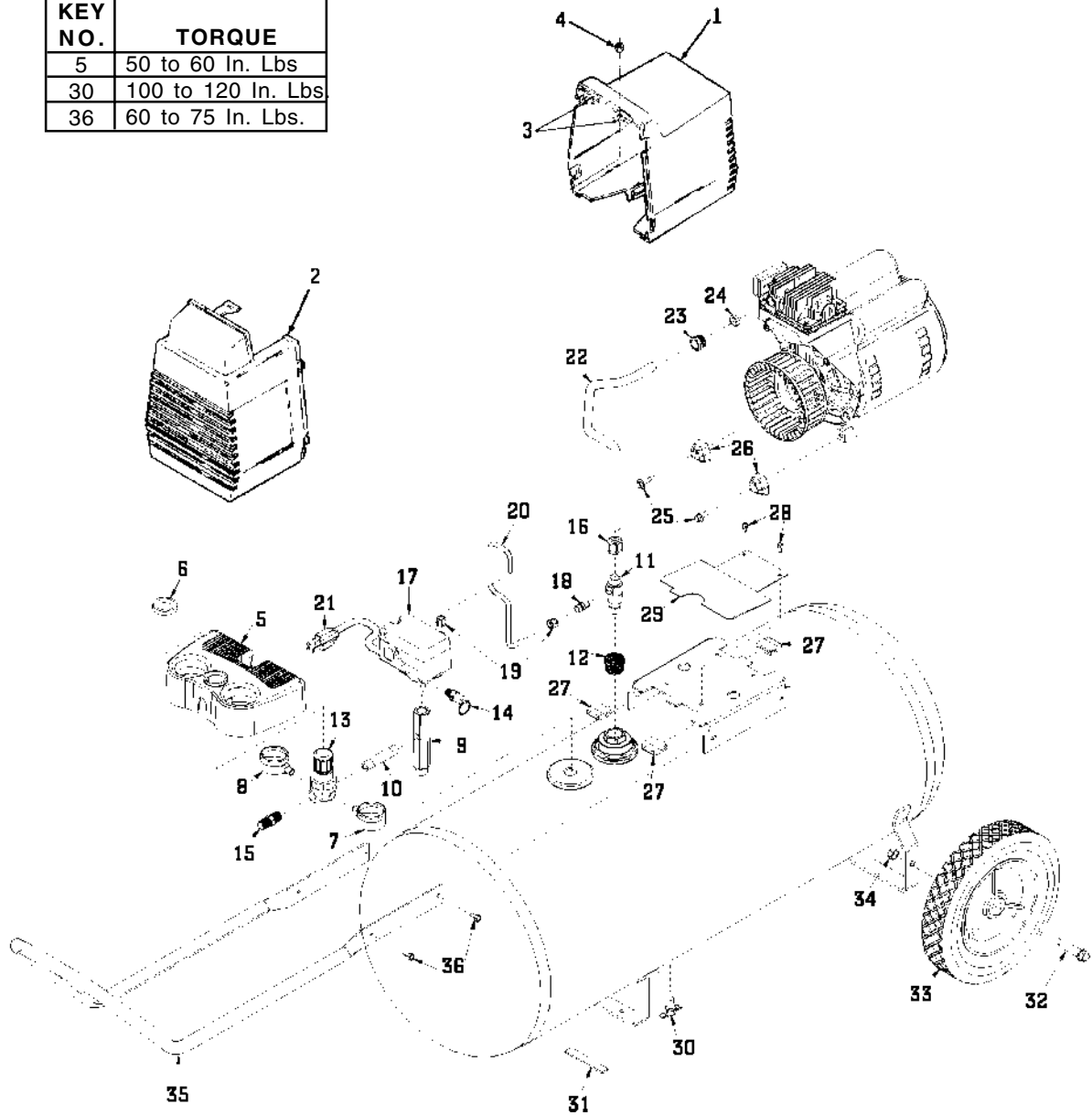

F18-4 (cont'd)

KEY

<u>NO.</u>	<u>PART NUMBER</u>	<u>DESCRIPTION</u>
1	AC-0055	Shroud, Rear
2	AC-0078	Shroud, Front
3	CAC-1121	Bracket (2 used)
4	SS-655-ZN	Hex Nut 1/4" - 20 (2 used)
5	AC-0011	Console, Cover
6	CAC-61	Ring, Panel Mounting
7	AC-0009-1	Gauge, RT Hand
8	AC-0010-1	Gauge, LT Hand
9	AC-0027-2	Manifold
10	SSP-480	Nipple, 1/4 x 2.5"
11	CAC-4290-3	Check Valve
12	SSP-490	Reducer
13	AC-0007	Regulator
14	97503734	Safety Valve
15	H-2101	Adaptor
16	SSP-7813	Nut/Sleeve Assy.
17	AC-0008-2	Pressure Switch
18	SS-8553	Connector Body
19	SSP-7811	Nut/Sleeve Assy. (2 used)
20	AC-0160	Pressure Relief Tube
21	SUDL-403-1	Cord Assembly
22	AC-0125	Outlet Tube
23	SSP-7821-1	Nut Brass Compression
24	SSG-3105	O-Ring
25	91895680	Screw, (1/4-20 x .75) (2 used)
26	ACG-18	Cup, Saddle Mount (2 used)
27	ACG-19	Isolator (3 used)
28	SSF-953-ZN	Screw 10 x 5/8 (2 used)
29	AC-0047	Fan Guard
30	SS-2707	Drain Valve
31	SUDL-6-1	Strip, Rubber Foot
32	CAC-60	Shoulder Bolt (2 used)
33	CAC-4299	Wheel - 6" (2 used)
34	SSF-8080-ZN	Nut, Hex 3/8" (3/8-16 unc-2B - 2 used)
35	AC-0563	Handle
36	SSF-981	Screw (4 used)

NOT ILLUSTRATED

KK-4315 Pressure Relief Valve

F18-4 (cont'd)

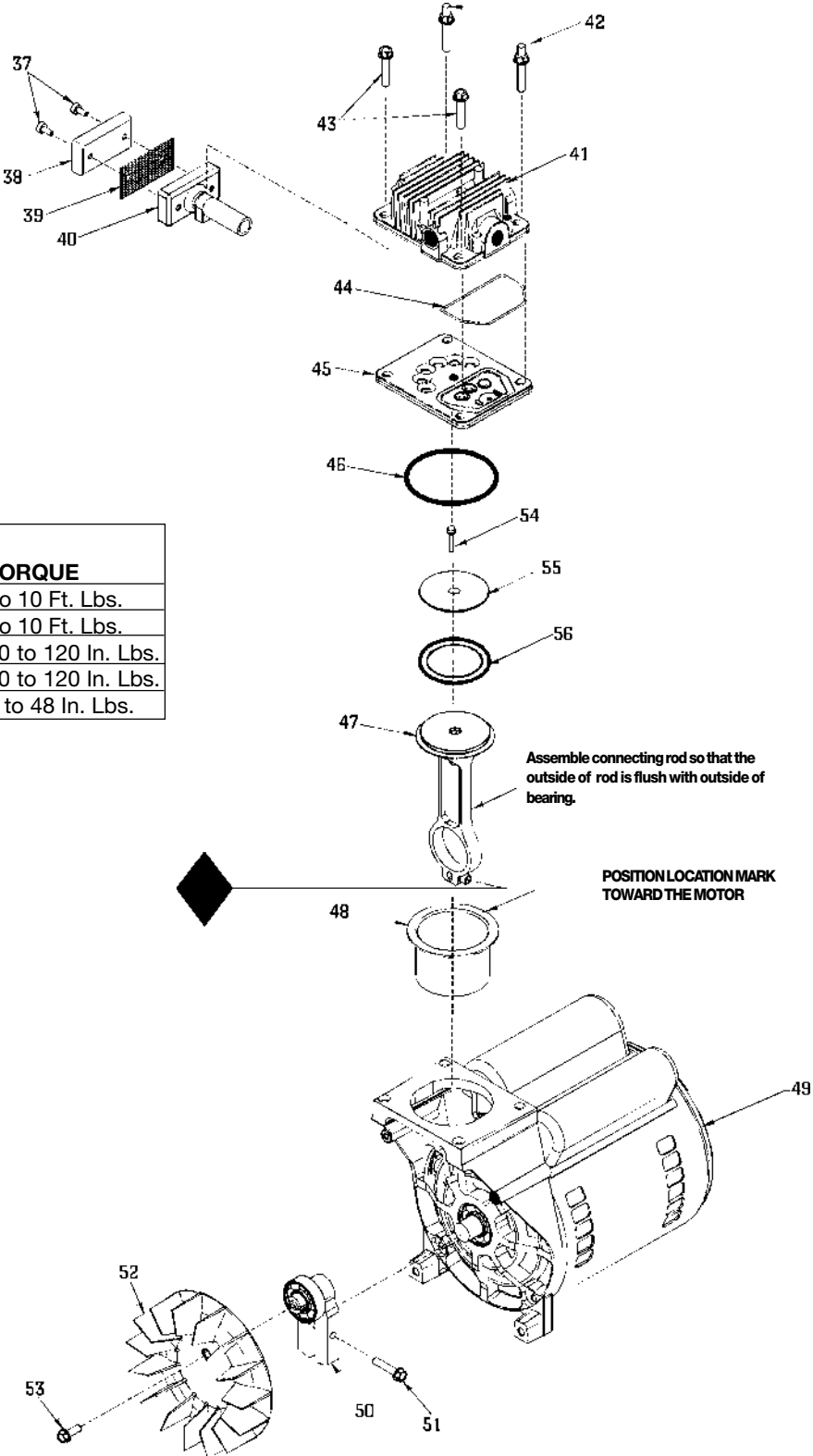

KEY NO.	TORQUE
42	7 to 10 Ft. Lbs.
43	7 to 10 Ft. Lbs.
51	100 to 120 In. Lbs.
53	100 to 120 In. Lbs.
◆	42 to 48 In. Lbs.

F18-4 (cont'd)

KEY	NO.	PART NUMBER	DESCRIPTION
+	37	---	Air filter fastener (2 used)
	38	DAC-143	Air filter
+	39	---	Muffler screen
+	40	---	Intake muffler
	41	AC-0037	Head
	42	SSF-589	Stud 1/4"-20 x 1 1/4"
	43	SSF-927	Screw 1/4-20 x 1 1/4"
✓*	44	ACG-45	O-Ring
	45	AC-0032	Valve plate assembly (includes valves, restrictors & screws)
✓*	46	SSG-8156	O-ring
*	47	---	Connecting rod assembly
*✓	48	---	Cylinder sleeve (position locating mark toward motor)
	49	M0-9047-1	Motor
	50	AC-0140	Eccentric Flywheel Bearing Assy.
	51	SSF-990	Screw (1/4-20 unc-2A)
	52	AC-0108	Fan
	53	SSF-586	Screw (1/4-20 unc x .75)
*✓	54	SSF-3158-1	Screw 10-24 X .75 T25 Torx
*	55	---	Compression Ring Connecting Rod Cap
*✓	56	---	Compression Ring

NOT ILLUSTRATED

MG2-OFTANK-4A	Owners Manual
MP2-F18-4A	Parts Manual

- + KK-4981 (also includes Key #38).
- * KK-4835 piston/cylinder kit.
- ✓ K-0058 cylinder sleeve/compression ring kit.