

F212 F220

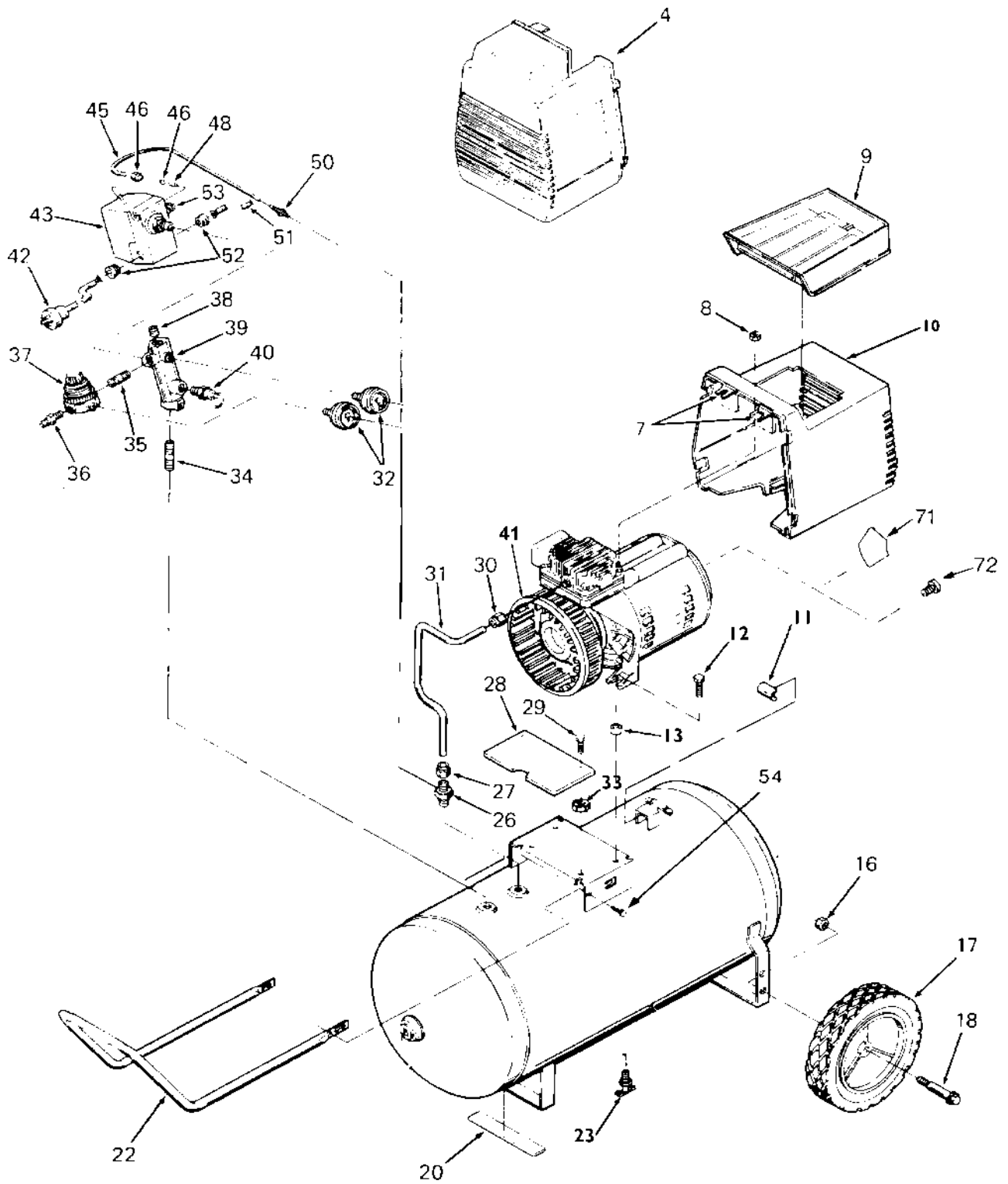

F212

F220 (cont'd)

KEY NO.	PART NUMBER	DESCRIPTION
4	CAC-1140	Shroud - front
7	CAC-1121	Bracket (2 used - included with #10)
8	SS-655-ZN	Hex Nut 1/4"-20 (2 used)
9	CAC-1080	Tool tray
10	CAC-1082-1	Rear shroud assembly (includes 2 ea. #7)
11	CAC-1099	U-Channel isolator
12	SSF-505	Shoulder screw (2 used)
13	CAC-1098	Isolator (2 used)
16	SSF-8080-ZN	Nut 3/8"-16 (2 used)
17	CAC-4293	Wheel 8" (2 used)
18	CAC-60	Shoulder bolt 3/8"-16 x 2 1/4" (2 used)
20	SUDL-6-1	Rubber foot strip
22	CAC-1304-1	Handle (black finish)
23	SS-2707	Drain Valve
26	CAC-4290-3	Check Valve
27	SSP-7813	Nut sleeve assembly (for 3/8" O.D. Tube)
28	AC-0155	Shroud Plate
29	SSF-1000	Ratchet Fastener (2 used)
30	SSP-7821	Nut (tighten until it stops against head)
31	CAC-1155	Outlet tube
32	GA-352	Pressure Gauge (2 used)
33	SSN-62	Nylon Spacer
34	SS-2072	Nipple (3/8" NPT x 1 1/2" long)
35	SS-2071	Nipple (1/4" NPT x 1 1/2" long)
36	H-2099	Adapter
37	CAC-4296-1	Regulator
38	SS-3222-CD	Pipe plug 1/4" NPT
39	CAC-1327	Manifold
40	97503734	Safety valve ASME
41	CAC-1120	Silicone Sleeve
42	SUDL-403-1	Cord assembly - line
43	CAC-4221-1	Pressure switch
45	CAC-1085	Pressure relief tube (warm tube before installing on #50)
46	SSP-7811	Nut sleeve assembly (1/4")
48	SSP-9013	Tube insert
50	SSP-6088	Barbed fitting
51	CAC-4215-1	Cord assembly - motor
52	SSW-7367	Strain relief (2 used)
53	KK-4315	Pressure release valve and mounting nut (included with #43)
54	SSF-981	Screw 1/4" AB x 3/4" long (4 used)

F212

F220 (cont'd)

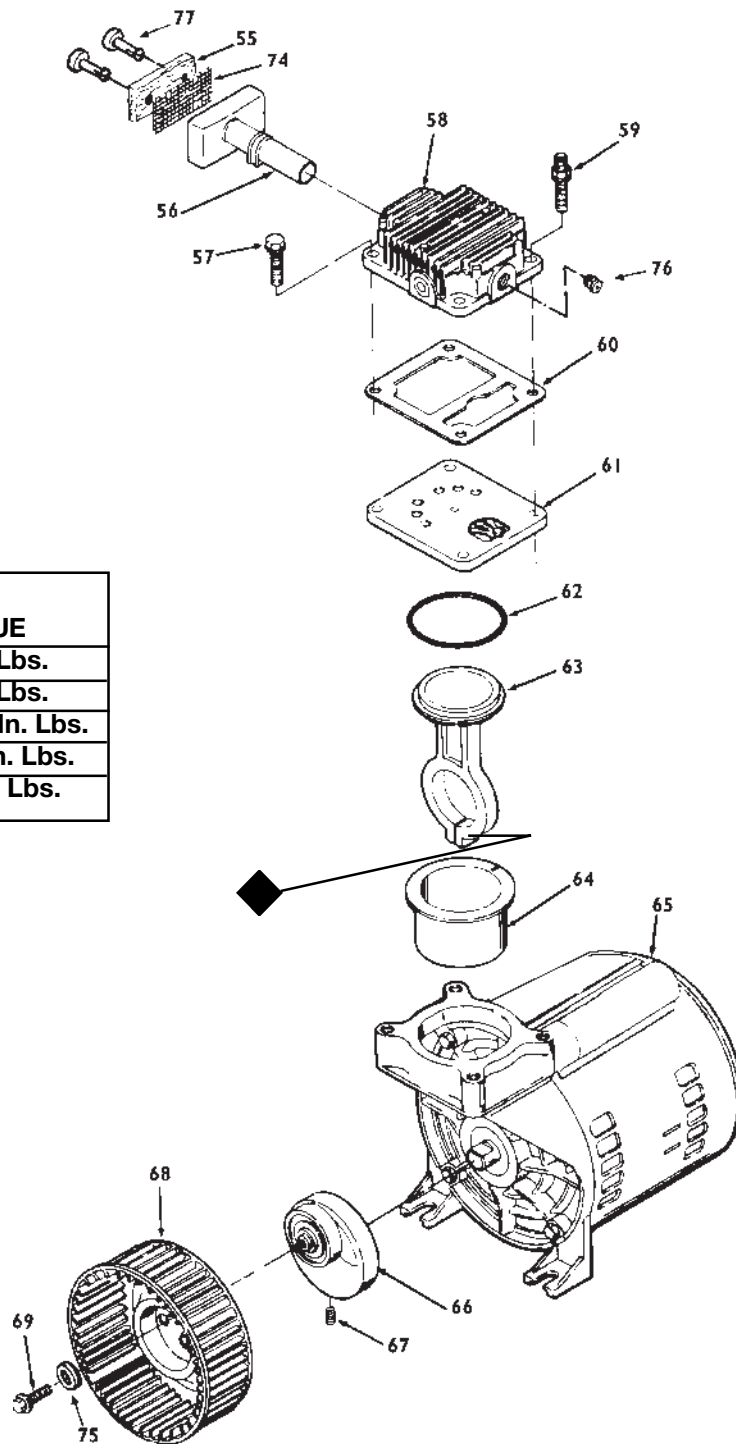

KEY NO.	TORQUE
59	7 to 10 Ft. Lbs.
57	7 to 10 Ft. Lbs.
67	100 to 120 In. Lbs.
69	80 to 100 In. Lbs.
◆	42 to 48 In. Lbs.

F212

F220 (cont'd)

KEY NO.	PART NUMBER	DESCRIPTION
+ 55	DAC-143	Air Filter
+ 56	CAC-1046-1	Intake muffler
57	SSF-990	Screw 1/4"-20 x 1 1/4" (2 used)
58	ACG-26	Head
59	SSF-6640	Stud 1/4"-20 x 1 1/4" (2 used)
60	ACG-45	O-ring
61	Z-ACG-402	Valve plate assembly (includes valves, restrictors & screws)
* 62	SSG-8156	O-ring
* 63	---	Connecting rod assembly
* 64	---	Cylinder sleeve (position locating mark toward motor)
65	MO-3018-4	Motor 2 HP
66	Z-CAC-4086	Eccentric Flywheel Bearing Assy.
67	SSF-3153	Screw
X 68	----	Squirrel Cage Fan
X 69	----	Screw #10-24 x 3/8" long
71	CAC-1415	Terminal box cover
72	SUDL-9-1	Ground screw
+ 74	DAC-142	Muffler screen
X 75	----	Washer
76	SS-3222-CD	Pipe plug
+ 77	----	Air Filter Fastener

NOT ILLUSTRATED

H-7038	Air Hose 1/4" ID x 15'
H-5797	Air Hose 1/4" ID x 25'
SSH-20	Air Chuck
MG2-OFTANK-4A	Owners Manual (F212 & F220)
MP2-F212-1	Parts Manual (F212 & F220)

+ Key No's. 55, 56, 74 and 77 can only be purchased as part of kit KK-4977.

* Key No's 62, 63 and 64 can only be purchased as part of kit KK-4835.

X Key No's 68, 69 and 75 can only be purchased as part of kit KK-5018.