

F2520-2

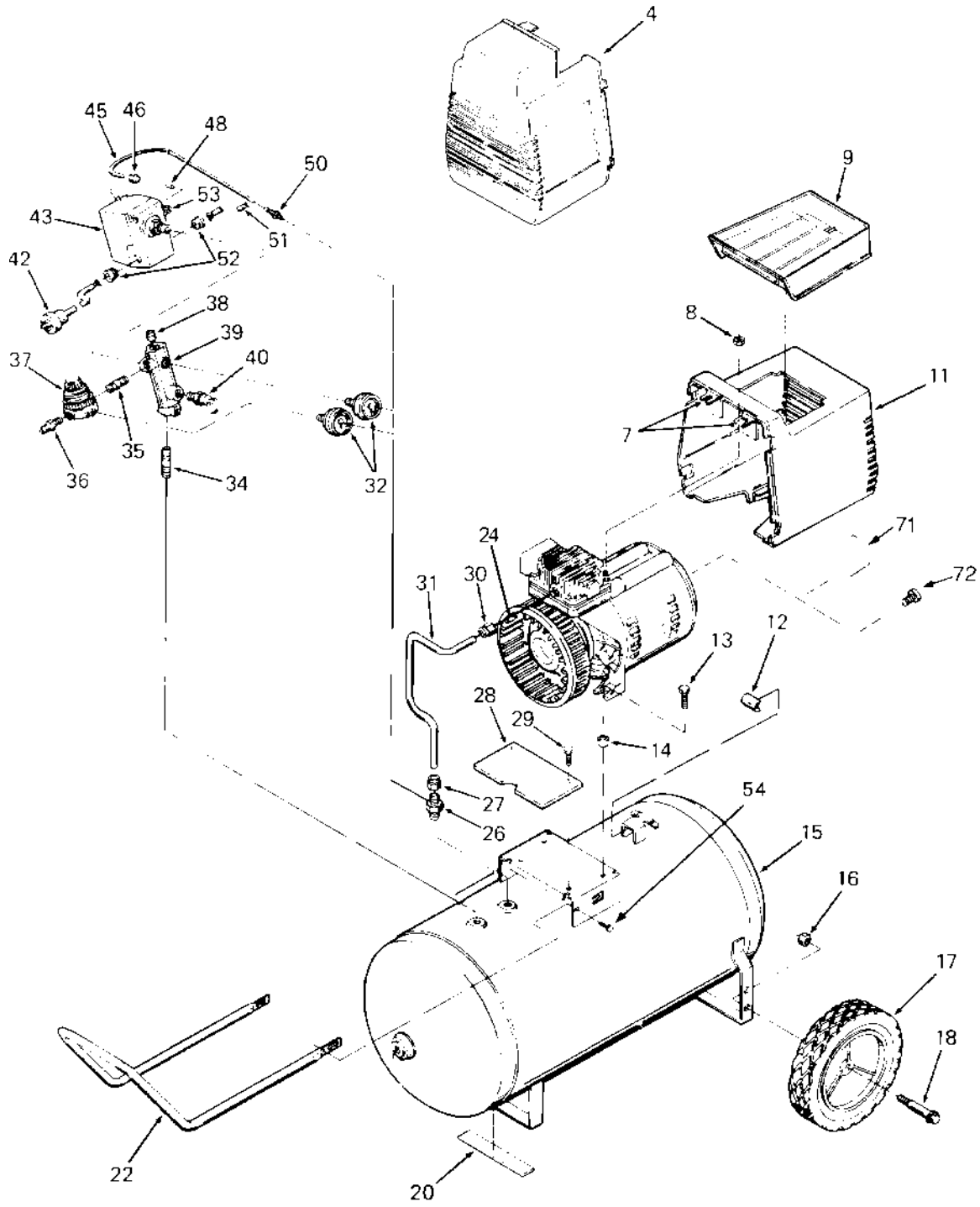

F2520-2 (cont'd)

KEY

<u>NO.</u>	<u>PART NUMBER</u>	<u>DESCRIPTION</u>
4	CAC-1140	Shroud - front
7	CAC-1121	Bracket (2 used - included with #10)
8	SS-655-ZN	Hex Nut 1/4"-20 (2 used)
9	CAC-1080	Tool tray
11	CAC-4317	Rear shroud assembly (includes 2 ea. #7)
12	CAC-1099	U-Channel isolator
13	SSF-505	Shoulder screw (2 used)
14	CAC-1098	Isolator (2 used)
15	-----	-----
16	SSF-8080-ZN	Nut 3/8"-16 (2 used)
17	CAC-4293	Wheel 8" (2 used)
18	CAC-60	Shoulder bolt 3/8"-16 x 2 1/4" (2 used)
19	-----	-----
20	SUDL-6-1	Rubber foot strip
22	CAC-1304-1	Handle (black finish)
24	CAC-1120	Silicone Sleeve
26	CAC-4290-3	Check valve
27	SSP-7813	Nut sleeve assembly (for 3/8" O.D. Tube)
28	AC-0155	Shroud Plate
29	SSN-8001	Screw (2 used)
30	SSP-7821-1	Nut (tighten until it stops against head)
31	CAC-1155	Outlet tube
32	C-GA-362	Pressure Gauge (2 used)
34	SS-2072-1	Nipple (3/8" NPT x 1 1/2" long)
35	SS-2071	Nipple (1/4" NPT x 1 1/2" long)
36	H-2099	Adapter
37	CAC-4296-1	Regulator
38	SS-3222-CD	Pipe plug 1/4" NPT
39	CAC-365	Manifold
40	TIA-4125	Safety valve ASME
42	SUDL-403-1	Cord assembly - line
43	CAC-4220-2	Pressure switch
45	CAC-1085	Pressure relief tube (warm tube before installing on #50)
46	SSP-7811	Nut sleeve assembly (1/4")
48	SSP-9013	Tube insert
50	SSP-6088	Barbed fitting
51	CAC-4215-1	Cord assembly - motor
52	SSW-7367	Strain relief (2 used)
53	KK-4315	Pressure release valve and mounting nut (included with #43)
54	SSF-981	Screw 1/4" AB x 3/4" long (4 used)

F2520-2 (cont'd)

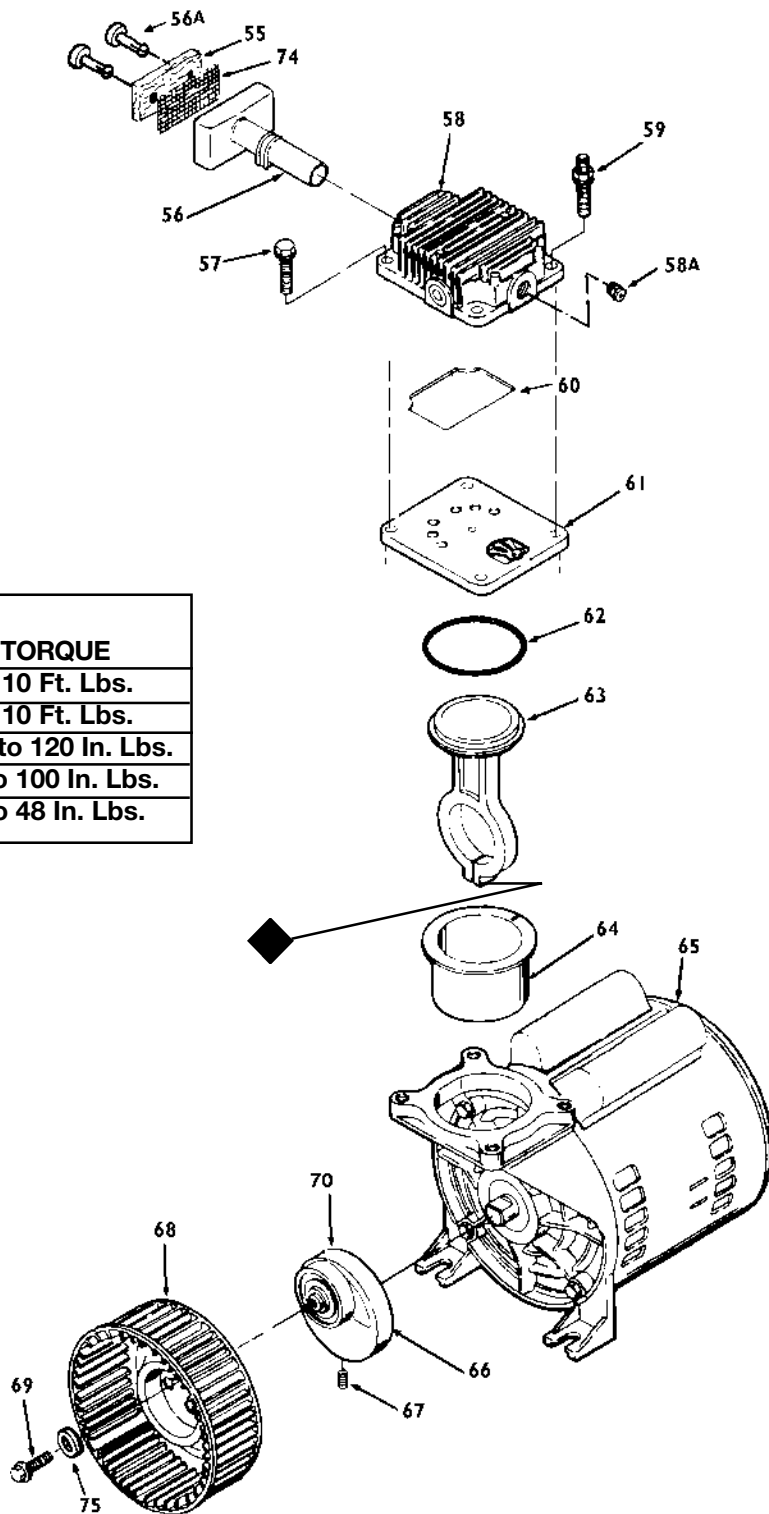

KEY NO.	TORQUE
59	7 to 10 Ft. Lbs.
57	7 to 10 Ft. Lbs.
67	100 to 120 In. Lbs.
69	80 to 100 In. Lbs.
◆	42 to 48 In. Lbs.

F2520-2 (cont'd)

KEY	NO.	PART NUMBER	DESCRIPTION
	55	DAC-143	Air Filter
	56	-----	Intake muffler
	57	SSF-990	Screw 1/4"-20 x 1 1/4" (2 used, torque 7-10 Ft. Lbs.)
+	58	ACG-26	Head
+	59	SSF-6640	Stud 1/4"-20 x 1 1/4" (2 used, torque 7-10 Ft. Lbs.)
*	60	ACG-45	Gasket
	61	ACG-402	Valve plate assembly (includes valves, restrictors & screws)
*	62	SSG-8156	O-ring
*	63	---	Connecting rod assembly
*	64	---	Cylinder sleeve (position locating mark toward motor)
	65	C-MO-3018-3	Motor 2 HP
	66	CAC-4086	Eccentric Flywheel Bearing Assy.
	67	SSF-3155	Screw (eccentric, torque 50-60 In. Lbs.)
/	68	-----	Squirrel Cage Fan
/	69	-----	Screw #10-24 x 3/8" long (torque 30-35 In. Lbs.)
	74	-----	Muffler screen
/	75	-----	Washer
+	76	DAC-140	Flow Valve
	77	-----	Air Filter Fastener

NOT ILLUSTRATED

H-7038	Air Hose 1/4" ID x 15'
H-5797	Air Chuck
SS-2707	Drain Valve
MG2-OFTANK-4A	General Manual
MP2-F2520-2	Parts Manual

- * Keys 60, 62, 63 and 64 can only be purchased as part of KK-4835 connecting rod kit..
- + Keys 58, 60, and 76 are purchased as part of KK-4987 Kit.
- Keys 55, 56, 74 and 77 can be purchased as part of KK-4977 Kit.
- / Keys 68, 69, and 75 can be purchased as part of KK-5018 Fan Kit.