

F3530-1

F3530-2

KEY NO.	TORQUE
5	50 to 60 In. Lbs
30	100 to 120 In. Lbs.
36	60 to 75 In. Lbs.

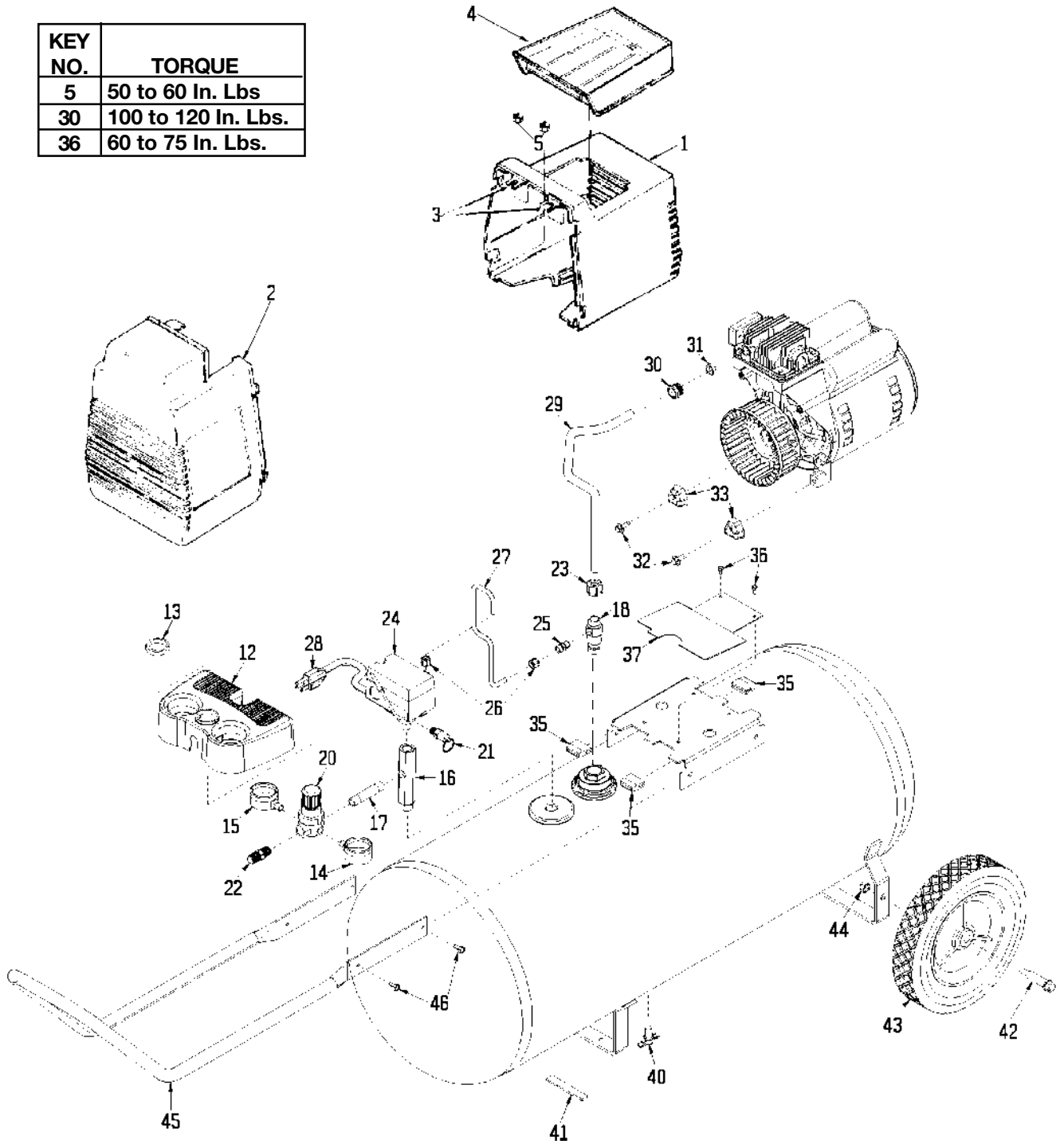

F3530-1

F3530-2 (cont'd)

KEY NO.	<u>PART NUMBER</u>	<u>DESCRIPTION</u>
1	AC-0049	Shroud, Rear
2	AC-0077	Shroud, Front
3	CAC-1121	Bracket (2 used)
4	CAC-1080	Tool Tray
5	SS-655-ZN	Hex Nut 1/4" - 20 (2 used)
12	AC-0011	Console, Cover
13	CAC-61	Ring, Panel Mounting
14	AC-0009-1	Gauge, RT Hand
15	AC-0010-1	Gauge, LT Hand
16	AC-0027-2	Manifold
17	SSP-480	Nipple, 1/4 x 2.5"
18	CAC-4290-3	Check Valve
20	AC-0007	Regulator
21	97503734	Safety Valve
22	H-2101	Adaptor
23	SSP-7813	Nut/Sleeve Assy.
24	AC-0008	Pressure Switch
25	SS-8553	Connector Body
26	SSP-7811	Nut/Sleeve Assy. (2 used)
27	AC-0160	Pressure Relief Tube
28	SUDL-413-2	Cord Assembly
29	AC-0125	Outlet Tube
30	SSP-7821-1	Nut Brass Compression (3 used)
31	SSG-3105	Silicone Sleeve
32	91895680	Screw, 1/4-20 x .75 (2 used)
33	ACG-18	Cup, Saddle Mount (2 used)
35	ACG-19	Isolator (3 used)
36	SSF-953-ZN	Screw 10 x 5/8 (2 used)
37	AC-0047	Shroud Plate
40	SS-2707	Drain Valve
41	SUDL-6-1	Strip, Rubber Foot
42	CAC-60	Shoulder Bolt (2 used)
43	CAC-4313	Wheel - 10" (2 used)
44	SSF-8080-ZN	Nut, Hex 3/8-16 unc - 2B 2 (used)
45	AC-0564	Handle
46	SSF-981	Screw (4 used)

F3530-1

F3530-2 (cont'd)

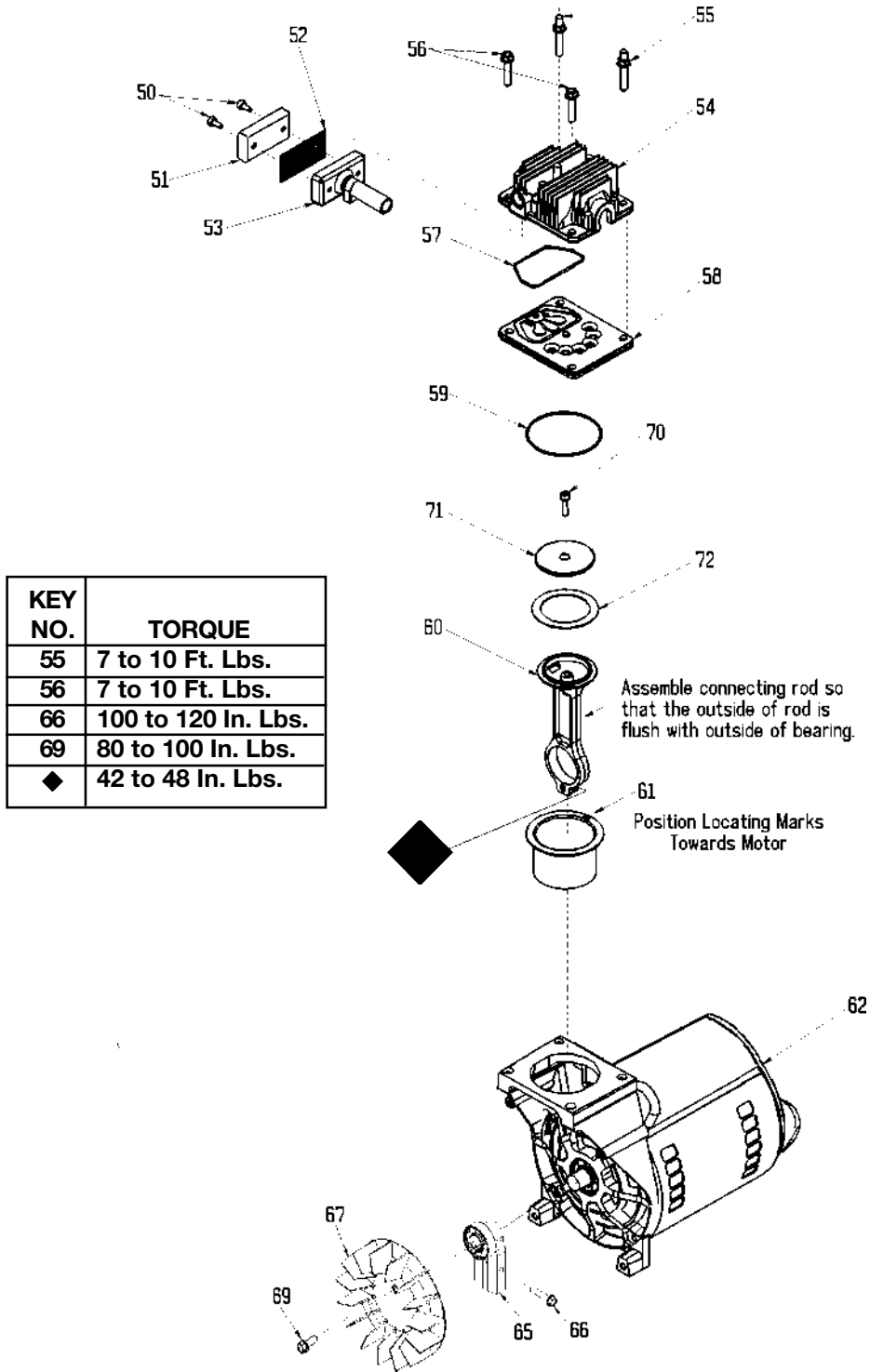

F3530-1

F3530-2 (cont'd)

KEY NO.	<u>PART NUMBER</u>	<u>DESCRIPTION</u>
+ 50	---	Air filter fastener (2 used)
51	DAC-143	Air filter
+ 52	---	Muffler screen
+ 53	---	Intake muffler
54	AC-0037	Head
55	SSF-589	Stud 1/4"-20 x 1 1/4"
*✓ 56	SSF-927	Screw 1/4-20 x 1 1/4"
57	ACG-45	O-Ring
58	Z-AC-0032	Valve plate assembly (includes valves, restrictors & screws)
*✓		
* 59	SSG-8156	O-ring
*✓ 60	---	Connecting rod assembly
61	---	Cylinder sleeve (position locating mark toward motor)
62	Z-M0-9047-1	Motor
65	Z-AC-0140	Eccentric Flywheel Bearing Assy.
66	SSF-615	Screw 1/4 unc-2A
67	AC-0108	Fan
*✓ 69	SSF586	Screw 1/4-20 unc x .75
* 68		
*✓ 70	SSF-3158-1	Screw 10-24 X .75 T25 Torx
71	---	Connecting Rod Cap
72	---	Compression Ring

NOT ILLUSTRATED

SST-5314-1	Rubber Foot (4 used)
MG2-OFTANK-4A	General Manual
MP2-F3530-2	Parts Manual

- + Keys 50, 52 and 53 can only be purchased as part of KK-4981 (also includes Key #51).
- * Keys 57, 59, 60, 61, 71 and 72 can only be purchased as part of KK-4835 connecting rod kit.
- \ Keys 67, 68 and 69 can only be purchased as part of KK-5018 fan kit.
- ✓ Keys 57, 59, 61, 70 and 72 can be purchased as part of K-0058 cylinder sleeve/compression ring kit.