

F420-1 FC420

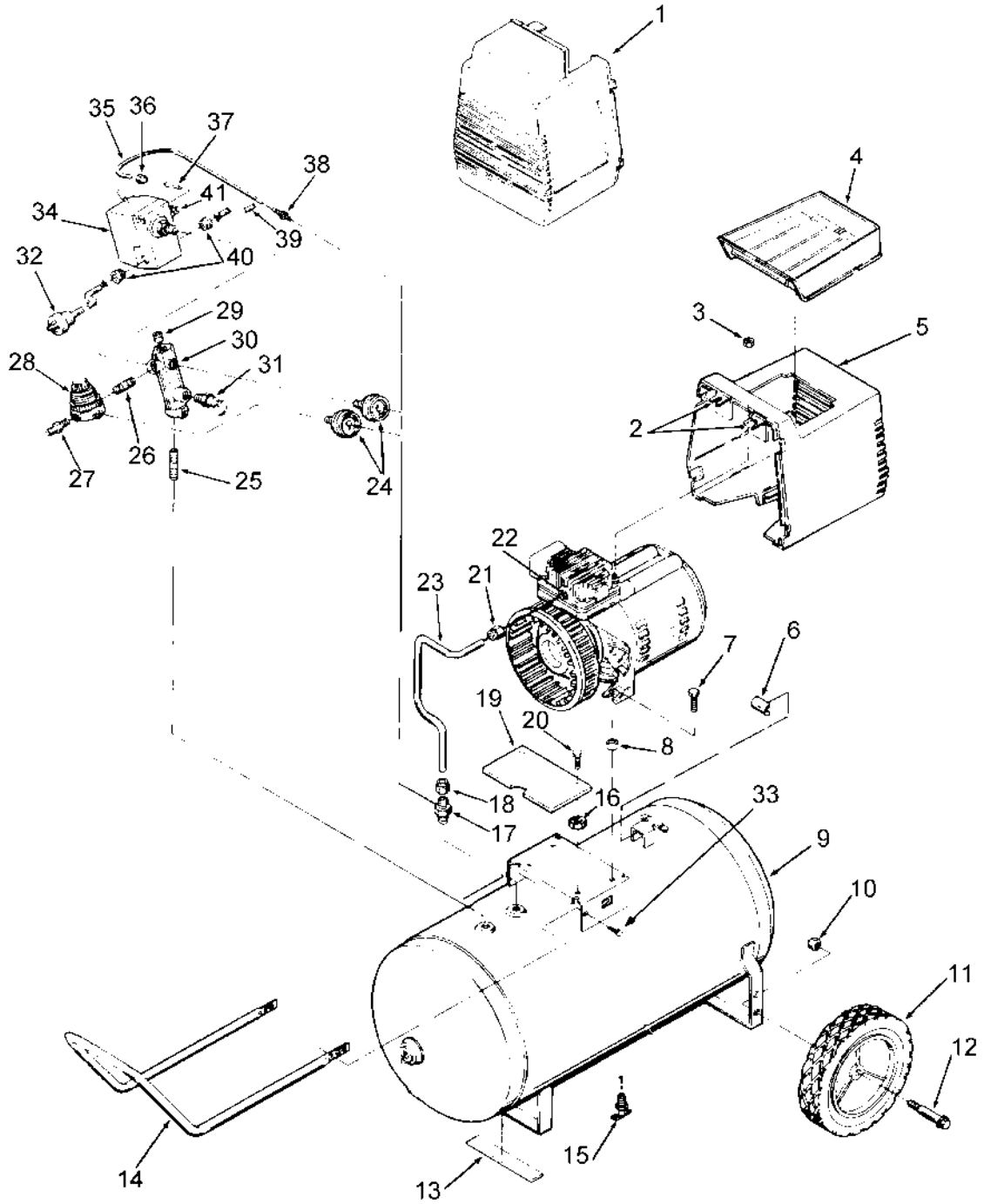

F420-1

FC420 (cont'd)

KEY NO.	PART NUMBER	DESCRIPTION
1	AC-0078	Shroud - front
2	CAC-1121	Bracket (2 used - included with #10)
3	SS-655-ZN	Hex Nut 1/4"-20 (2 used)
4	CAC-1080	Tool tray
5	CAC-1082-2	Rear shroud assembly (includes 2 ea. #7)
6	CAC-1099	U-Channel isolator
7	SSF-505	Shoulder screw (2 used)
8	CAC-1098	Isolator (2 used)
10	SSF-8080-ZN	Nut 3/8"-16 (2 used)
11	CAC-4313	Wheel (2 used)
12	CAC-60	Shoulder bolt 3/8"-16 x 2 1/4" (2 used)
13	SUDL-6-1	Rubber foot strip
14	CAC-1304-1	Handle
15	SS-2707	Drain Tank
16	SSN-62	Nylon Spacer (2 used)
17	CAC-4290-3	Check valve
18	SSP-7813	Nut sleeve assembly (for 3/8" O.D. Tube)
19	AC-0155	Shroud Plate
20	SSF-1000	#12-3/4 Hex Hd. Screw (2 used)
21	SSP-7821-1	Nut (tighten until it stops against head)
22	CAC-1120	Silicone Sleeve
23	CAC-1155	Outlet tube
24	GA-352	Pressure Gauge (2 used)
25	SS-2110	Nipple (3/8" NPT x 1 1/2" long)
26	SS-2071	Nipple (1/4" NPT x 1 1/2" long)
27	H-2099	Adapter
28	AC-0007	Regulator
29	SS-3222-CD	Pipe plug 1/4" NPT
30	CAC-365	Manifold
31	TIA-4150	Safety valve ASME
32	SUDL-413-2	Cord assembly - line
33	SSF-981	Handle Screw (4 used)
34	CAC-4221-3	Pressure switch
35	CAC-1085	Pressure relief tube (warm tube before installing on #50)
36	SSP-7811	Nut sleeve assembly (1/4")
37	SSP-9013	Tube insert
38	SSP-6088	Barbed fitting
39	CAC-4215-1	Cord assembly - motor to switch
40	SSW-7367	Strain relief (2 used)
41	KK-4315	Pressure release valve kit

F420-1 FC420 (cont'd)

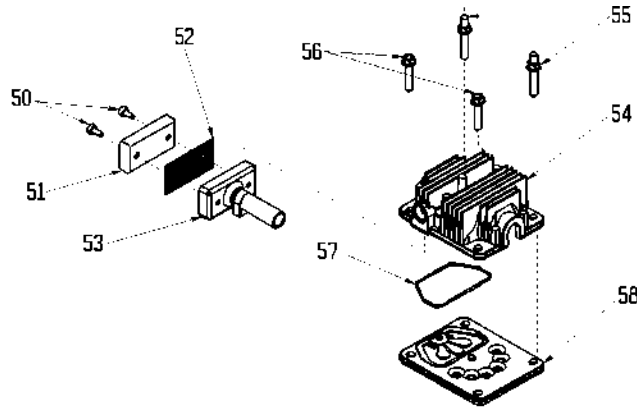

KEY NO.	TORQUE
55	7 to 10 Ft. Lbs.
56	7 to 10 Ft. Lbs.
66	100 to 120 In. Lbs.
69	80 to 100 In. Lbs.
◆	42 to 48 In. Lbs.

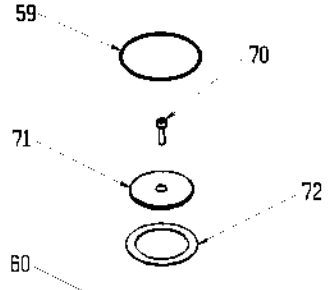

Assemble connecting rod so that the outside of rod is flush with outside of bearing.

61 Position Locating Marks Towards Motor

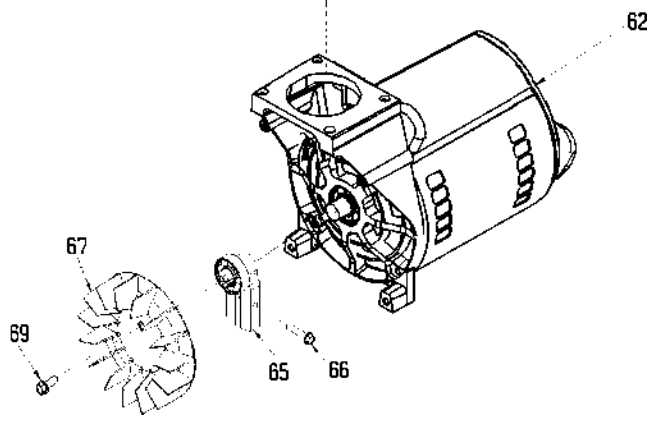

F420-1

FC420 (cont'd)

KEY	<u>NO.</u>	<u>PART NUMBER</u>	<u>DESCRIPTION</u>
	+ 50	---	Air filter fastener (2 used)
	+ 51	DAC-143	Air filter
	+ 52	---	Muffler screen
	+ 53	---	Intake muffler
	54	ACG-26	Head
	55	SSF-6640	Stud 1/4"-20 x 1 1/4"
	56	SSF-990	Screw 1/4-20 x 1 1/4"
	*✓ 57	ACG-45	O-Ring
	58	ACG-402	Valve plate assembly (includes valves, restrictors & screws)
	*✓ 59	SSG-8156	O-ring
	* 60	---	Connecting rod assembly
	*✓ 61	---	Cylinder sleeve (position locating mark toward motor)
	62	MO-9045	Motor
	65	AC-4086	Eccentric Flywheel Bearing Assy.
	66	SSF-3153	Screw 1/4-20 unc-2A
	\ 67	-----	Fan
	\ 68	-----	Washer
	\ 69	-----	Screw 1/4-20 unc x .75
	*✓ 70	SSF-3158-1	Screw 10-24 X .75 T25 Torx
	* 71	---	Compression Ring Connecting Rod Cap
	*✓ 72	---	Compression Ring

NOT ILLUSTRATED

H-7038	Air Hose
SSH-20	Air Chuck
H-7040-1	Air Hose
KK-4315	Pressure Relief Valve
MG2-OFTANK-4A	Owners Manual (F420-1 & FC420)
MP2-420-1	Parts Manual (F420-1)
MP2-FC420	Parts Manual (F420)

- * Keys 57, 59, 60, 61, 70, 71 and 72 can only be purchased as part of KK-4835 Connecting Rod Kit.
- + Keys 50, 51, 52 and 53 can only be purchased as part of KK-4981
- \ Keys 67, 68 and 69 can be purchased as part of KK-5018 Fan Kit.
- ✓ Keys 57, 61, 70 and 72 can be purchased as part of K-0058 Cylinder Sleeve/ Compression Ring Kit.