

F5020 FC5020

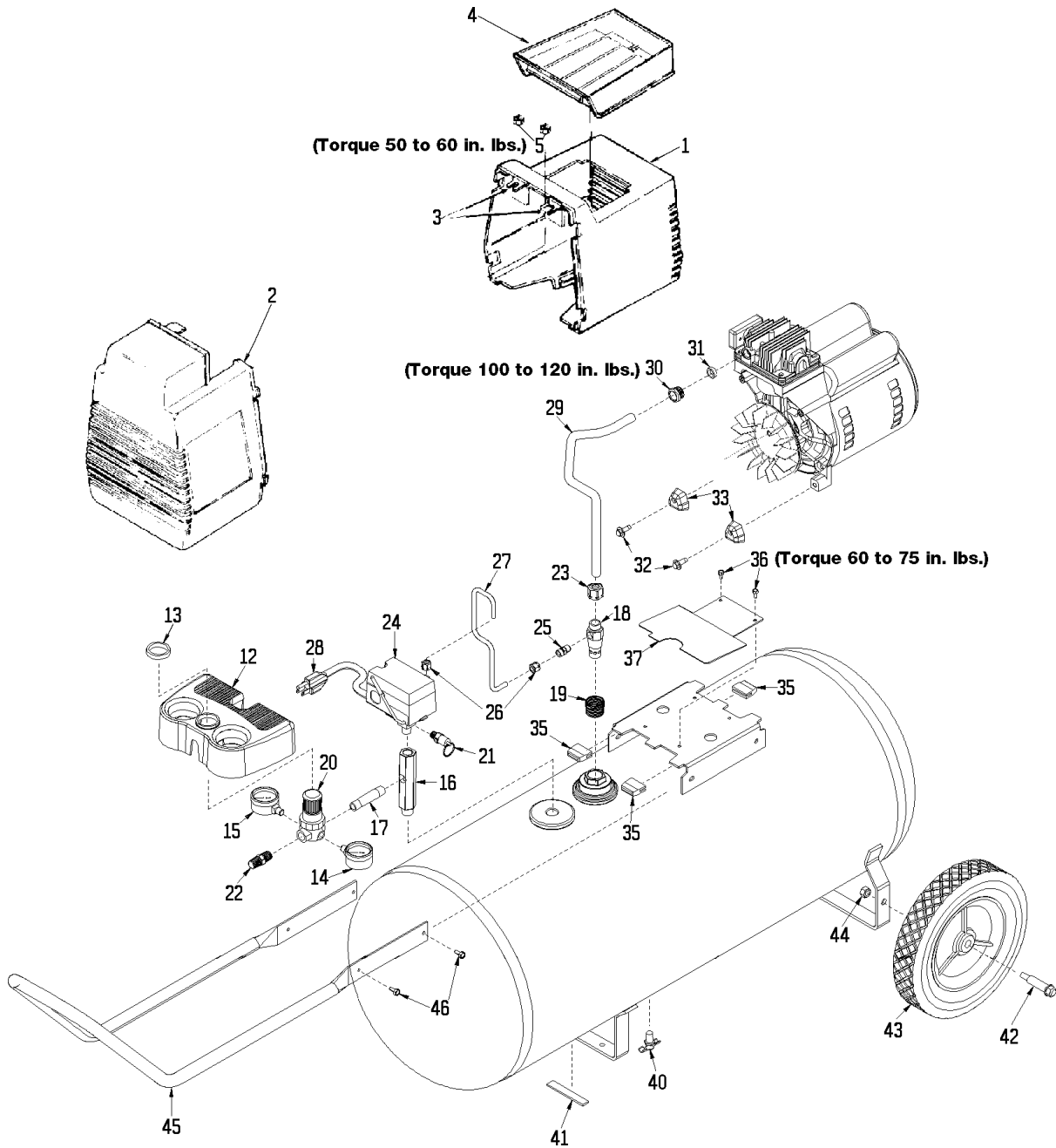

F5020

FC5020 (cont'd)

KEY NO.	PART NUMBER	DESCRIPTION
1	AC-0046	Shroud, Rear
2	AC-0078	Shroud, Front
3	CAC-1121	Bracket (2 used)
4	CAC-1080	Tool Tray
5	SS-655-ZN	Hex Nut 1/4" - 20 (2 used)
12	AC-0011	Console, Cover
13	CAC-61	Ring, Panel Mounting
14	AC-0009-1	Gauge, RT Hand
15	AC-0010-1	Gauge, LT Hand
16	AC-0027-2	Manifold
17	SSP-480	Nipple, 1/4 x 2.5"
18	CAC-4290-3	Check Valve
19	SSP-485-1	Reducer
20	AC-0007	Regulator
21	97503734	Safety Valve
22	H-2101	Adaptor
23	SSP-7813	Nut/Sleeve Assy.
24	AC-0008-2	Pressure Switch
25	SS-8553	Connector Body
26	SSP-7811	Nut/Sleeve Assy. (2 used)
27	AC-0028	Pressure Relief Tube
28	SUDL-413-2	Cord Assembly
29	AC-0125	Outlet Tube
30	SSP-7821-1	Brass Compression Nut
31	SSG-3105	Silicone Sleeve
32	91895680	Screw, 1/4-20 x .75 (2 used)
33	ACG-18	Cup, Saddle Mount (2 used)
35	ACG-19	Isolator (3 used)
36	SSF-953-ZN	Screw 10 x 5/8 (2 used)
37	AC-0047	Shroud Plate
40	SS-2707	Drain Valve
41	SUDL-6-1	Strip, Rubber Foot
42	CAC-60	Shoulder Bolt (2 used)
43	AC-0014	Wheel - 9" (2 used)
44	SSF-8080-ZN	Nut, Hex 3/8-16 unc - 2B (2 used)
45	AC-0563	Handle
46	SSF-981	Screw (4 used)
<u>NOT ILLUSTRATED</u>		
	KK-4315	Pressure Relief Valve
	DAC-161	Shim (FC5020)
	K-0157	Motor Start Capacitor

F5020 FC5020 (cont'd)

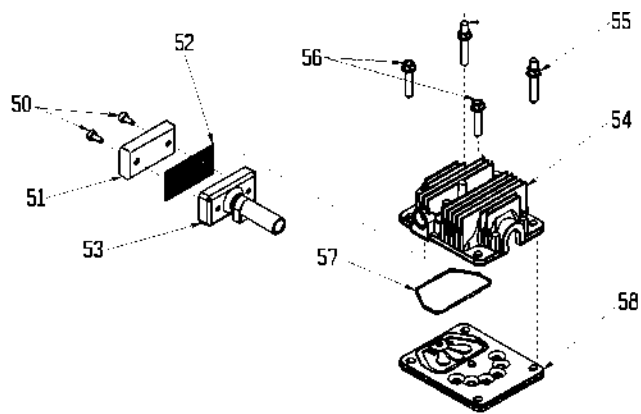

KEY NO.	TORQUE
55	7 to 10 Ft. Lbs.
56	7 to 10 Ft. Lbs.
66	100 to 120 In. Lbs.
69	80 to 100 In. Lbs.
◆	42 to 48 In. Lbs.

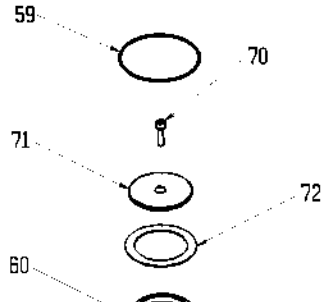

Assemble connecting rod so that the outside of rod is flush with outside of bearing.

61
Position Locating Marks Towards Motor

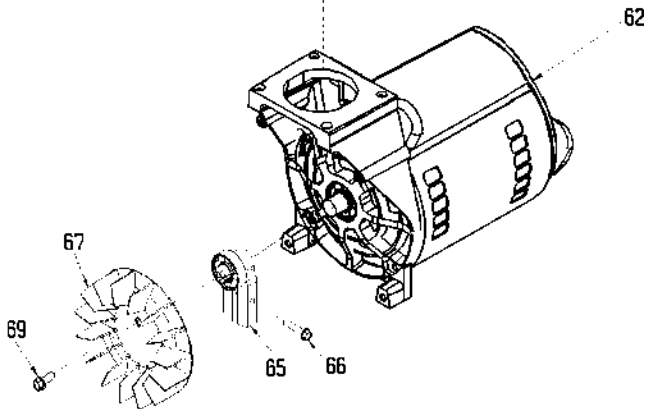

F5020

FC5020 (cont'd)

KEY	NO.	PART NUMBER	DESCRIPTION
	+ 50	---	Air filter fastener (2 used)
	* 51	DAC-143	Air filter
	+ 52	---	Muffler screen
	+ 53	---	Intake muffler
	54	AC-0037	Head
	55	SSF-589	Stud 1/4"-20 x 1 1/4"
	56	SSF-927	Screw 1/4-20 x 1 1/4"
	*✓ 57	ACG-45	O-Ring
	58	AC-0032	Valve plate assembly (includes valves, restrictors & screws)
	*✓ 59	SSG-8156	O-ring
	+* 60	---	Connecting rod assembly
	*✓ 61	---	Cylinder sleeve (position locating mark toward motor)
	62	Z-M0-9045	Motor
	65	AC-0140	Eccentric Flywheel Bearing Assy.
	66	SSF-990	Screw 1/4-20 unc-2A
	67	AC-0108	Fan
	69	SSF-586	Screw 1/4-20 unc x .75
	*✓ 70	SSF-3158-1	Screw 10-24 X .75 T25 Torx
	* 71	---	Compression Ring Connecting Rod Cap
	*✓ 72	---	Compression Ring

NOT ILLUSTRATED

KK-4315	Pressure Relief Valve
MG2-OFTANK-4A	General Manual
MP2-F5020C	Parts Manual

- + Keys 57, 59, 60, 61, 70, 71 and 72 can only be purchased as part of KK-4835 Connecting Rod Kit.
- * Keys 50, 52 and 53 can only be purchased as part of KK-4981 (also includes Key #51).
- ✓ Keys 57, 61, 70 and 72 can be purchased as part of K-0058 Cylinder Sleeve/Compression Ring Kit.