

FB5020

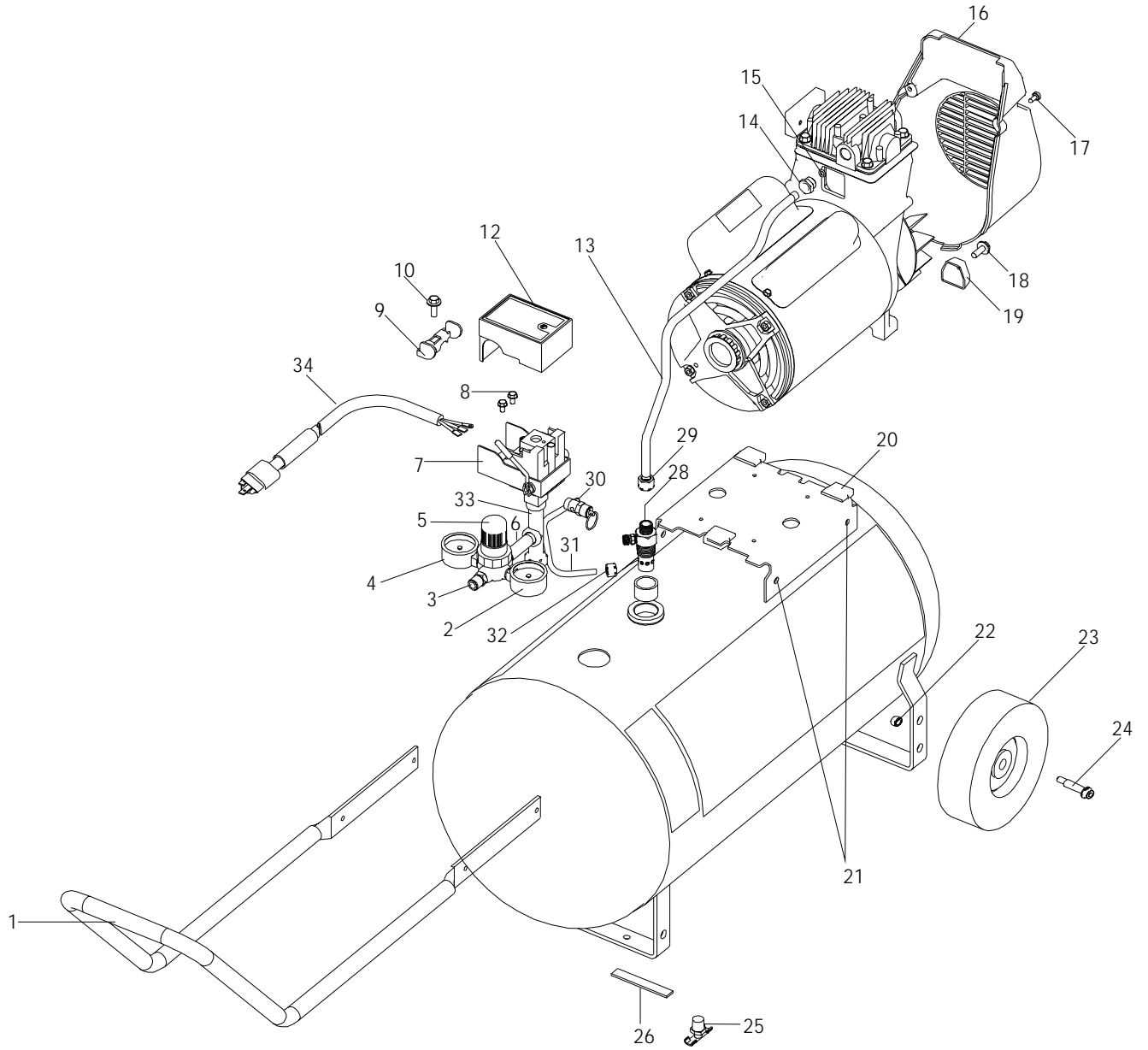

FB5020 (cont'd)

| KEY NO. | PART NUMBER | DESCRIPTION |
|--------------------|-------------------------|-----------------------------------|
| 1 | AC-0563 | Handle |
| 2 | AC-0009-1 | Gauge, RT Hand |
| 3 | H-2101 | Adaptor |
| 4 | AC-0010-1 | Gauge, LT Hand |
| 5 | AC-0007 | Regulator |
| 6 | SSP-480 | Nipple, 1/4 x 2.5" |
| 7 | AC-0565 | Pressure Switch |
| 8 | SSF-1001-1 | Ground Screw (2 used) |
| 9 | CAC-1392 | Strain Relief |
| 10 | SSF-556 | Screw, 10-32 x 1 |
| 12 | AC-0556 | Pressure Switch Cover |
| 13 | AC-0568 | Outlet Tube |
| 14 | SSP-7821-1 | Brass Compression Nut |
| 15 | SSG-3105 | Silicone Sleeve |
| 16 | AC-0376 | Mini Shroud |
| 17 | ACG-408 | Fastener Assembly (2 used) |
| 18 | 91895680 | Screw, 1/4-20 x .75 (2 used) |
| 19 | ACG-18 | Cup, Saddle Mount (2 used) |
| 20 | ACG-19 | Isolator (3 used) |
| 21 | SSF-981 | Screw (4 used) |
| 22 | SSF-8080-ZN | Nut, Hex 3/8-16 unc - 2B (2 used) |
| 23 | AC-0014 | Wheel - 9" (2 used) |
| 24 | CAC-60 | Shoulder Bolt (2 used) |
| 25 | SS-2707 | Drain Valve |
| 26 | SUDL-6-1 | Strip, Rubber Foot |
| 28 | AC-0631 | Check Valve |
| 29 | SSP-7813 | Nut/Sleeve Assy. 3/8" |
| 30 | 97503734 | Safety Valve |
| 31 | AC-0654 | Pressure Relief Tube |
| 32 | SSP-7811 | Nut Sleeve Assy. |
| 33 | AC-0027-2 | Manifold |
| 34 | SUDL-413-2 | Cord Assembly |
| | <u>NOT SHOWN</u> | |
| | DAC-161 | Shim (FBC5020) |

FB5020 (cont'd)

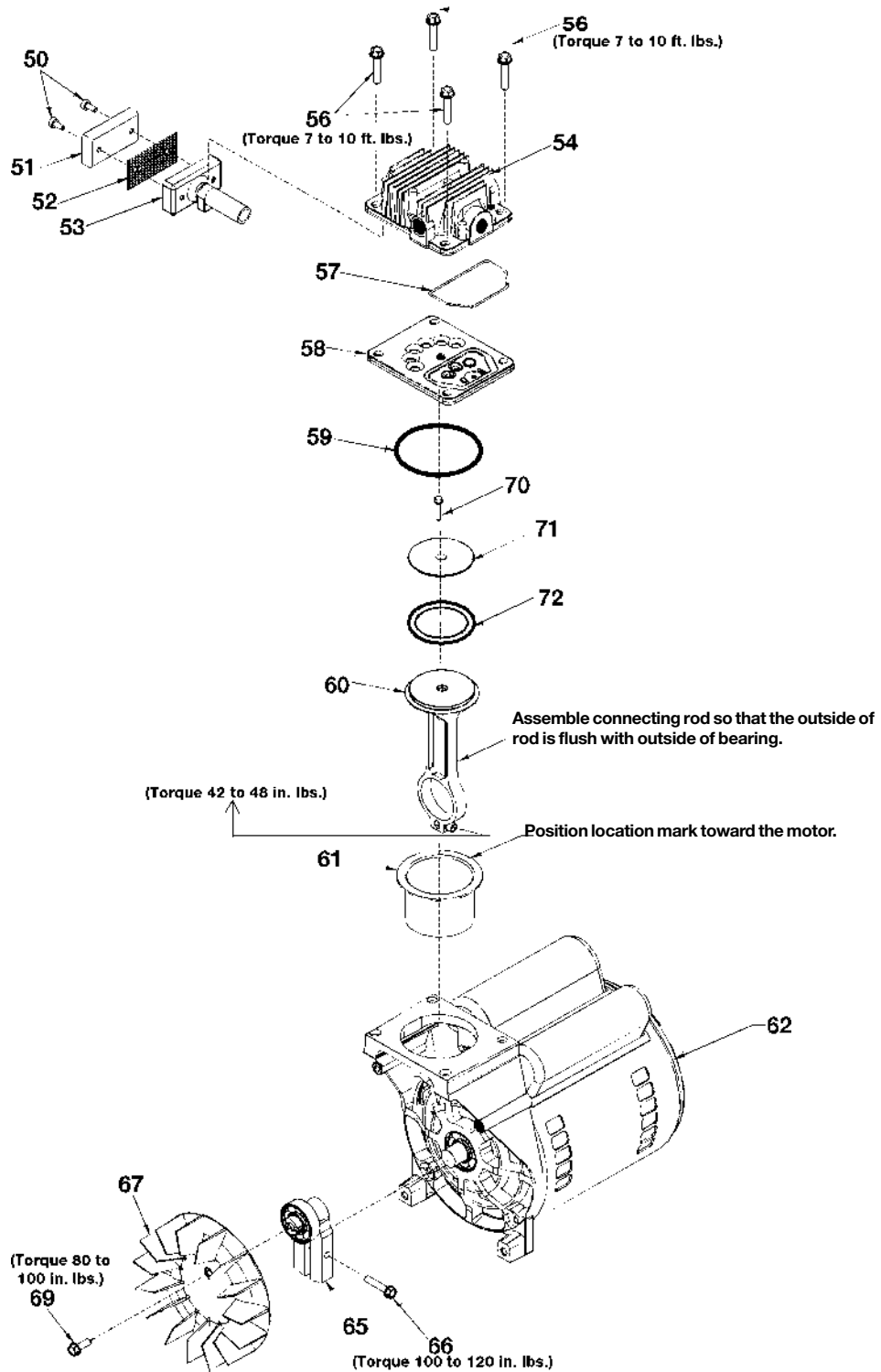

FB5020 (cont'd)

| KEY | | |
|------------|--------------------|--|
| NO. | PART NUMBER | DESCRIPTION |
| + 50 | --- | Air filter fastener (2 used) |
| + 51 | DAC-143 | Air filter |
| + 52 | --- | Muffler screen |
| + 53 | --- | Intake muffler |
| 54 | AC-0037 | Head |
| 56 | SSF-927 | Screw 1/4-20 x 1 1/4" (4 used) |
| *✓ 57 | ACG-45 | O-Ring |
| 58 | AC-0032 | Valve plate assembly (includes valves, restrictors & screws) |
| *✓ 59 | SSG-8156 | O-ring |
| * 60 | --- | Connecting rod assembly |
| *✓ 61 | --- | Cylinder sleeve (position locating mark toward motor) |
| 62 | M0-9075 | Motor |
| 65 | AC-0140 | Eccentric Flywheel Bearing Assy. |
| 66 | SSF-615 | Screw (1/4-20 unc-2A) |
| 67 | AC-0108 | Fan |
| 69 | SSF-586 | Screw (1/4-20 unc x .75) |
| *✓ 70 | SSF-3158-1 | Screw 10-24 X .75 T25 Torx |
| * 71 | --- | Connecting Rod Cap |
| *✓ 72 | --- | Compression Ring |

NOT ILLUSTRATED

MG2-OFTANK-4A General Manual

MP2-FB5020C Parts Manual

- + KK-4981 (also includes Key Nos. 50, 51, 52, 53)
- * KK-4835 piston/cylinder kit (also includes Key Nos. 57, 59, 60, 61, 70, 71, 72)
- ✓ K-0058 cylinder sleeve/compression ring kit (also includes 57, 59, 61, 70, 72)