

FTV530-2

FCTV530-2

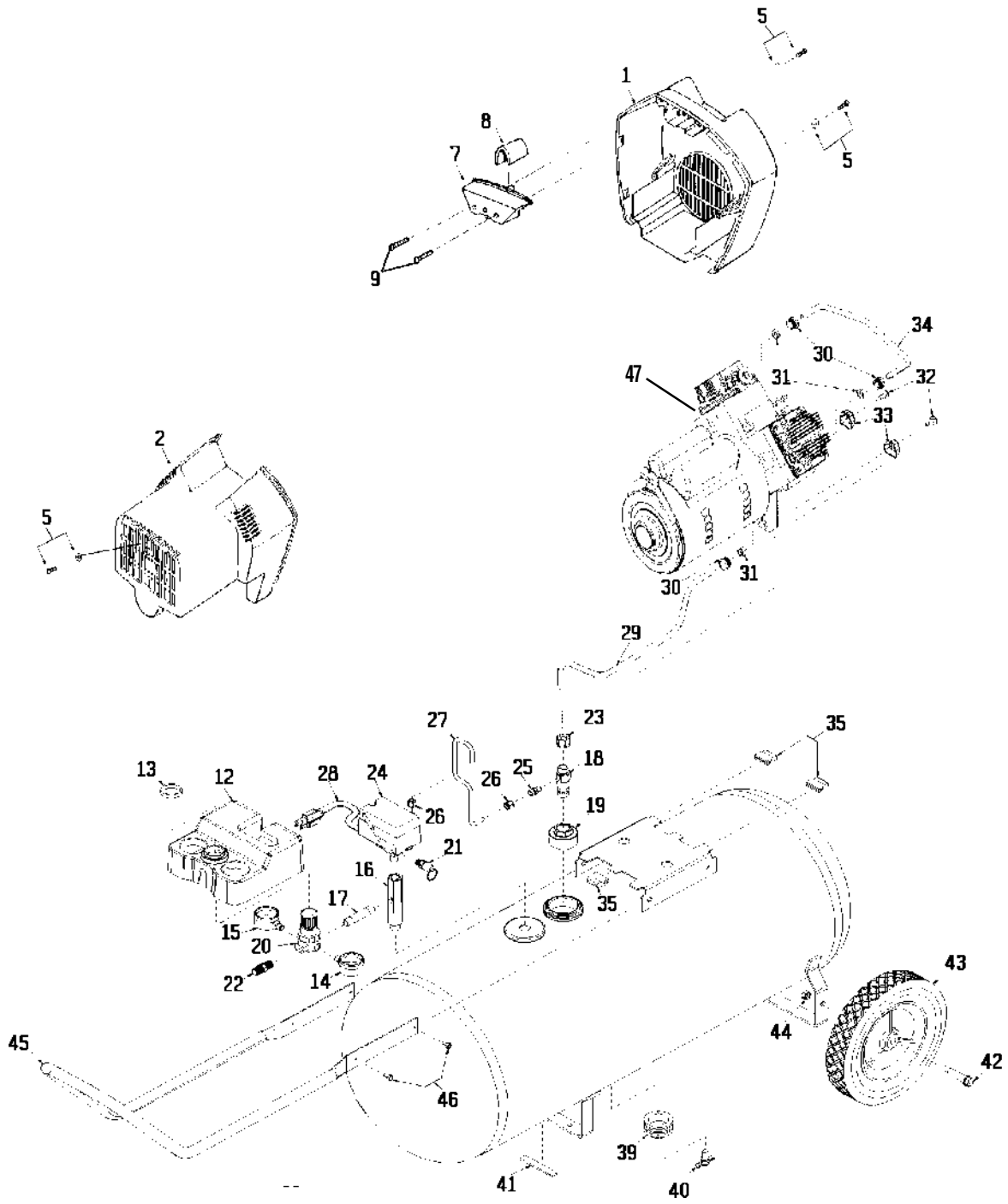

FTV530-2

FCTV530-2 (cont'd)

KEY NO.	PART NUMBER	DESCRIPTION
1	DAC-243	Shroud, Rear
2	DAC-244	Shroud, Front
5	ACG-408	Fastener Assembly (3 used: Torque 33-38 in.-lbs.)
7	ACG-13	Cover, Intake Muffler
8	ACG-12	Filter Element
9	SSF-554	Screw, #10-14 x 2.5 Pan Head (2 used)
12	AC-0011	Console, Cover
13	CAC-61	Ring, Panel Mounting
14	AC-0009-1	Gauge, RT Hand
15	AC-0010-1	Gauge, LT Hand
16	AC-0027-2	Manifold
17	SSP-480	Nipple, 1/4 x 2.5"
18	CAC-4290-3	Check Valve
19	SSP-485	Reducer
20	AC-0007	Regulator
21	97503734	Safety Valve
22	H-2101	Adaptor
23	SSP-7813	Nut/Sleeve Assy.
24	AC-0008-2	Pressure Switch
25	SS-8553	Connector Body
26	SSP-7811	Nut/Sleeve Assy. (2 used)
27	AC-0028	Pressure Relief Tube
28	SUDL-415-1	Cord Assembly
29	AC-0126	Outlet Tube
30	SSP-7821-1	Nut Brass Compression (3 used)
31	SSG-3105	Silicone Sleeve
32	SSF-990	Screw, 1/4 - 2 ounce - 2A THD Forming (2 used)
33	ACG-18	Cup, Saddle Mount (2 used)
34	AC-0099	Crossover Tube
35	ACG-19	Isolator (3 used)
39	SSP-470	Hex Reducer Bushing
40	SS-2707	Drain Valve
41	SUDL-6-1	Strip, Rubber Foot
42	CAC-60	Shoulder Bolt (2 used)
43	CAC-4313	Wheel - 10" (2 used)
44	SSF-8080-ZN	Nut, Hex 3/8" (2 used)
45	AC-0564	Handle
46	SSF-981	Screw (4 used)
*47	AC-0102	Pump Assembly

NOT SHOWN

H-7038	Air Hose (FTV530-2)
H-7040-1	Air Hose (FCTV530-2)
SSH-8	Air Chuck
KK-4315	Unloader Valve
MG7-OFTWIN	General Manual
MP7-FTV530-2	Parts Manual

** Refer to pump breakdowns*